

# TrueNAS® R50 User Manual

v.25121

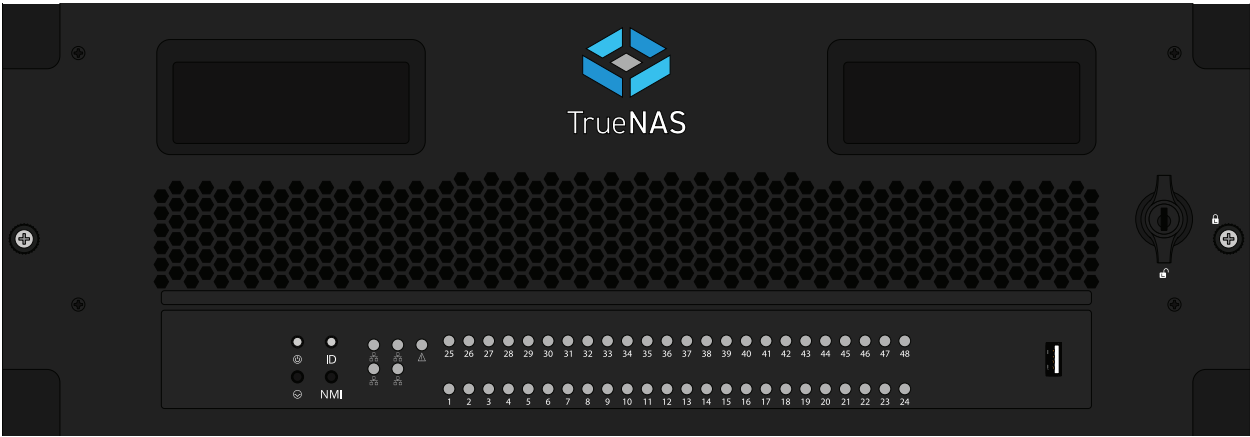

# Contents

<b>1</b>	<b>Introduction</b>	<b>1</b>
<b>2</b>	<b>Safety</b>	<b>3</b>
2.1	Anti-Static Precautions	3
2.2	Personal Protective Equipment (PPE)	3
2.3	Handling the System	3
<b>3</b>	<b>Recommended Tools</b>	<b>3</b>
<b>4</b>	<b>Specifications</b>	<b>4</b>
<b>5</b>	<b>Space Requirements</b>	<b>6</b>
<b>6</b>	<b>Buttons and LED Indicators</b>	<b>7</b>
6.1	Front Indicators and Buttons	7
6.2	Drive Slot Indicators	7
<b>7</b>	<b>Racking Procedure</b>	<b>8</b>
7.1	Install Cage Nuts	8
7.2	Install the Rack Rails	9
7.3	Adjust the Rail Sleeve	10
7.4	Install the Assist Rails	11
7.5	Mount the R50 in the Rack	12
7.6	Attach the Extended Ear Brackets (Optional)	13
<b>8</b>	<b>Managing Drives</b>	<b>14</b>
8.1	Open the Drive Drawer	14
8.2	Install Hard Drives	15
8.3	Close the Drive Drawer	16
<b>9</b>	<b>Install Cables</b>	<b>17</b>
9.1	10/40/100GbE NIC Cabling	18
9.2	1/10/25GbE or Fibre Channel NIC Cabling	19
9.3	Expansion Cabling	20
<b>10</b>	<b>Boot the System</b>	<b>21</b>
<b>11</b>	<b>Storage Expansion</b>	<b>22</b>
11.1	ES24	22
11.2	ES24F	24
11.3	ES102 Gen 1 and ES60 Gen 2	26
11.4	ES102 Gen 2	28
<b>12</b>	<b>Unracking Procedure</b>	<b>30</b>
12.1	Uninstall Cables	30
12.2	Open the Drive Drawer	30
12.3	Remove Hard Drives	31
12.4	Close the Drive Drawer	31
12.5	Remove the Extended Ear Brackets (Optional)	32
12.6	Unmount the R50 in the Rack	33
12.7	Uninstall the Assist Rails	33

12.8 Uninstall the Rack Rails .....	34
12.9 Uninstall Cage Nuts .....	35
<b>13 Drive Replacement .....</b>	<b>36</b>
13.1 HDDs .....	36
13.2 Remove NVMe Trays .....	36
13.3 Remove NVMe Drives .....	36
<b>14 Additional Resources .....</b>	<b>37</b>
<b>15 Contact Us .....</b>	<b>37</b>

# 1 Introduction

The TrueNAS R50 is a 4U, 48-bay, hybrid storage array with redundant power supplies.

Your system comes with the TrueNAS operating system preloaded.

Review the safety considerations and requirements before interacting with the R50.

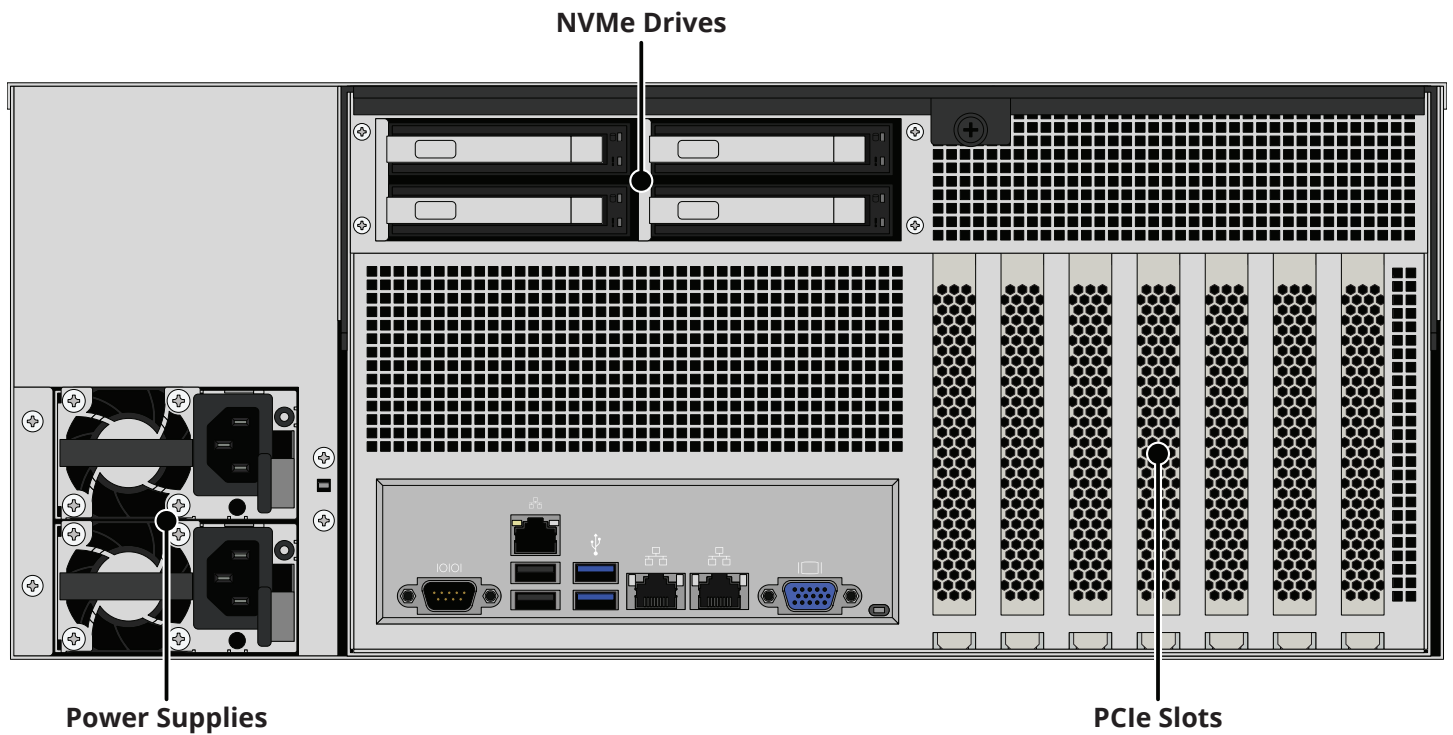
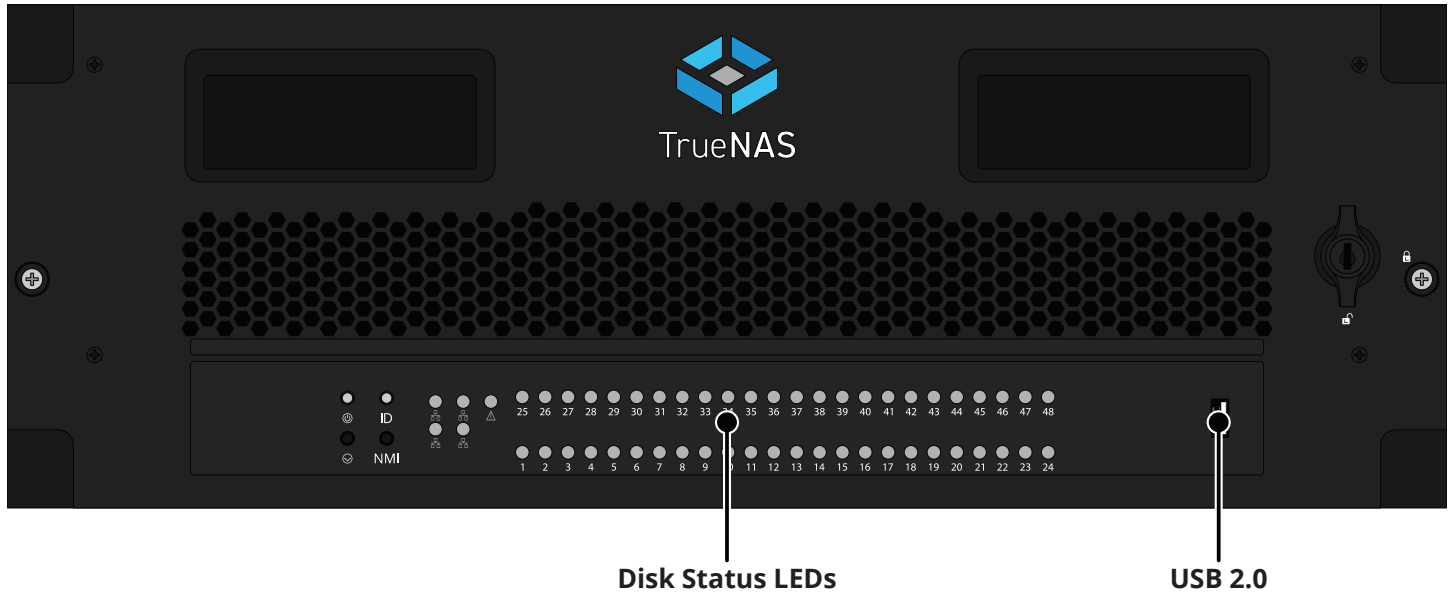

Drive Slots

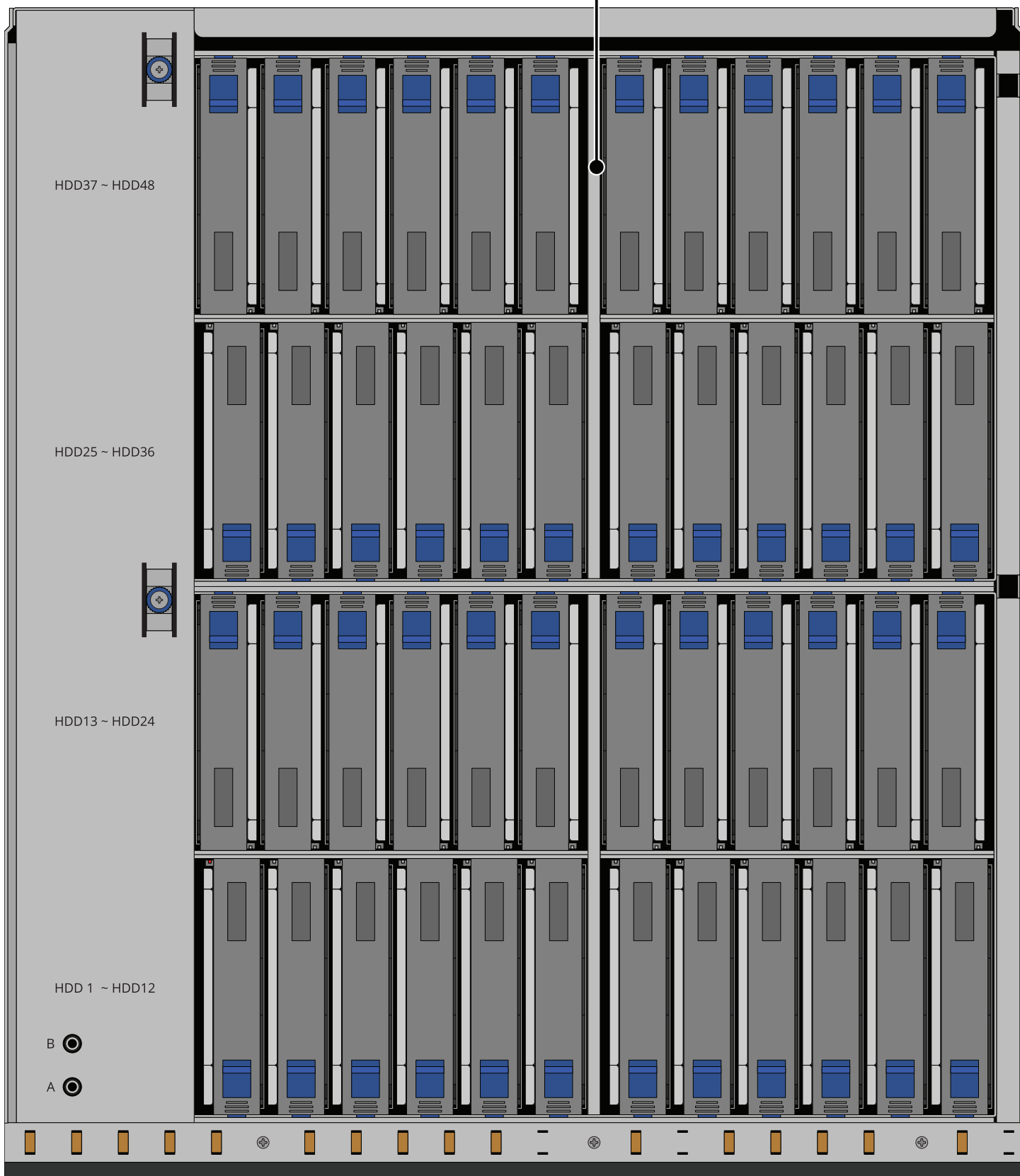

## 2 Safety

### 2.1 Anti-Static Precautions

#### ⚠ Warning - Electrostatic Discharge (ESD)

Static electricity can build up in your body and discharge when touching conductive materials. Electrostatic Discharge (ESD) is harmful to sensitive electronic devices and components. Keep these safety recommendations in mind before opening the system case or handling non-hot-swappable system components.

- Turn off the system and remove power cables before opening the case or touching internal components.
- Place the system on a clean, hard work surface like a wooden tabletop. Use an ESD dissipative mat if possible to protect the internal components.
- Touch the metal chassis with your bare hand to dissipate static electricity in your body before handling any internal components, including components not yet installed in the system. We always recommend wearing an anti-static wristband and using a grounding cable.
- Store all system components in anti-static bags.

### 2.2 Personal Protective Equipment (PPE)

#### ⚠ Warning - PPE

Wear proper PPE, like anti-static wrist straps and smocks before touching any sensitive equipment inside the chassis. If you are unsure how to properly replace any parts, contact iXsystems Support.

### 2.3 Handling the System

Hold the system from the sides or bottom whenever possible. Always be mindful of loose cabling or connectors, and avoid pinching or bumping these elements.

These instructions use “left” and “right” according to your perspective when facing the system or rack.

#### ⚠ Warning - Damage or Injury

The R50 weighs 183 lbs (83 kg) fully-loaded and requires a minimum of **two** people to lift.

When handling rails, system components, or drives, never force movement if a component seems stuck. Gently remove the component and check for pinched cables or obstructing material before installing it again. Installing a component with excessive force can damage the system or cause personal injury.

## 3 Recommended Tools

We recommend these tools when interacting with the TrueNAS R50:

- Long #2 Phillips head screwdriver
- Tape measure
- Level

## 4 Specifications

R50 Hardware	
Drive Count	48 3.5-inch SAS HDDs or SSDs + 4 2.5" (NVMe) SSDs
Cooling Fans	5
Power Supplies	2
Power Distribution Requirements	100V - 240V
Processor	6-16 cores
RAM	64 - 192 GB
Read Cache (Max)	4 x 3.2 or 4 x 15 TB NVMe SSD
Write Cache (Max)	4 x 3.2 TB NVMe SSD
Onboard Networking	2x 10 GbE
Additional Networking 1 (Optional)	2x 10/25/40/100 GbE
Additional Networking 2 (Optional)	2 or 6 x 100GbBaseT or SR
Max Storage (Raw)	5 PB
Storage Expansion	2 x ES102, ES24, or ES60

R50 Dimensions and Weight	
Dimensions (H x W x L)	7 in x 19 in x 39 in (178 mm x 483 mm x 990 mm)
Net Weight (Fully Loaded)	183 lbs (83 kg)

R50 Environmental Specifications	
Operating Temperature	41°F - 95°F (5°C - 35°C)
Non-Operating Temperature	-4°F - 158°F (-20°C - 70°C)
Max Heat Output	1000 BTU/h
Operating Humidity (non-condensing)	5% - 95%
Supply Voltage	100-240VAC, 10-5A 50-60 Hz

## Compliance



### MODEL NAME:

TrueNAS Model R50BM

**VOLTAGE:** 100-240VAC  
Current 10-5A Max (x2)

**FREQUENCY:** 50/60Hz

This device complies with Part 15 of the FCC rules. Operation is subject to the following two conditions: (1) This device may not cause harmful interference. (2) This device must accept any interference received, including interference that may cause undesired operation. 警語: 為避免電磁干擾, 本產品不應安裝或使用於住宅環境。

CAN ICES-3 (A) / NMB-3 (A)

**WARNING:** To remove all hazardous voltages, disconnect all power cords.



**CONTACT:** support@TrueNAS.com | www.truenas.com | 1-866-TRUENAS

The TrueNAS R50 is a network storage server intended for use in enterprise and data center environments.

### The apparatus is designed to be operated:

- In controlled IT environments, within the specified ranges for temperature, humidity, and supply voltage
- In properly grounded electrical installations, in accordance with local electrical codes
- In accordance with the TrueNAS software documentation, including configuration, operation, and maintenance instructions

### This product is not designed or intended for:

- Use in life-support systems or other safety-critical applications where failure could result in injury or loss of life
- Use in residential consumer environments, unless explicitly installed and operated in a controlled, non-domestic IT setting
- Any application outside the conditions and purposes described in this manual and the TrueNAS software documentation

For detailed configuration and operational guidance, refer to the TrueNAS software documentation provided with the product and available from TrueNAS.

The R50 is FCC/CE-marked and complies with:

- **FCC 47 CFR Part 15, Class A** - Radiated and conducted emissions limits for commercial IT equipment (EMI/EMC)
- **Low Voltage Directive (LVD) 2014/35/EU** - Electrical safety
- **Electromagnetic Compatibility (EMC) Directive 2014/30/EU** - Electromagnetic interference and immunity
- **RoHS Directive 2011/65/EU, as amended by (EU) 2015/863** - Restriction of hazardous substances
- **WEEE Directive 2012/19/EU** - Waste electrical and electronic equipment

For regulatory or compliance-related queries, contact [compliance@truenas.com](mailto:compliance@truenas.com).

EU Authorized Representative: Obelis S.A. - Boulevard Général Wahis 53, B-1030 Brussels, BELGIUM

## ⓘ Important - Battery Information

This product contains a lithium coin cell (CMOS battery) used to maintain system settings. Do not dispose of the battery with household waste. Used batteries must be collected and disposed of separately in accordance with local regulations and the EU Battery Directive 2006/66/EC. The crossed-out wheeled bin symbol indicates that the battery must be taken to an appropriate collection facility for recycling.

## 5 Space Requirements

### Note - Rack Space

The R50 requires 4U of rack space, 16 standard M5 cage nuts, and a #2 Phillips screwdriver to install in a rack.

The system is 39" (99.06 cm) long. Rack posts must be 23" - 35.75" (58.4 cm-90.8 cm) apart to install the rail kit.

The R50 requires an EIA-310-compliant rack. The front and rear rack posts can have a four-inch (101.6mm) tolerance in four different depth configurations.

The R50 has a built-in rail system that provides access to the drive drawer. We recommend at least 40" (1 m) of space in front of the rack to account for the drive drawer fully extended with personnel servicing it.

You must also have at least 30" (76.2 cm) of space behind the rack to install the cables.

The assist rails require another 1U of rack space underneath the R50.

### ⓘ Important - Damage or Injury

When handling rails, system components, or drives, never force movement if a part seems stuck or does not insert properly. Gently remove the part and check for pinched cables or obstructing material before installing it again. Installing a part with excessive force can damage the system or cause personal injury.

### ⚠ Warning - Team Lift

The R50 requires two people to lift safely. Failure to follow safety recommendations can lead to severe system damage or personal injury.

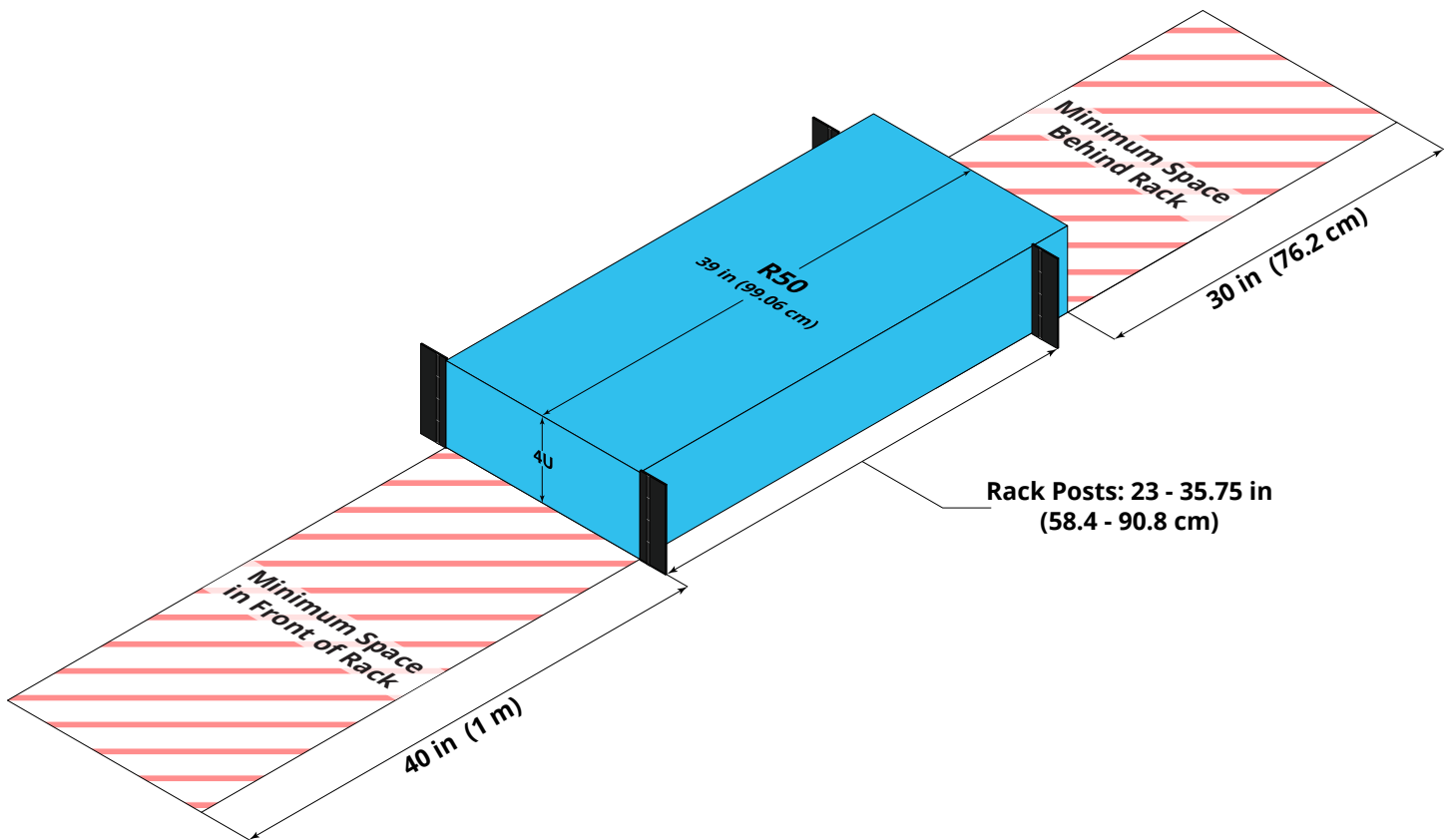



## 6 Buttons and LED Indicators

### 6.1 Front Indicators and Buttons

The R50 front panel has buttons and indicators to help control the system. It also has one USB 2.0 port.

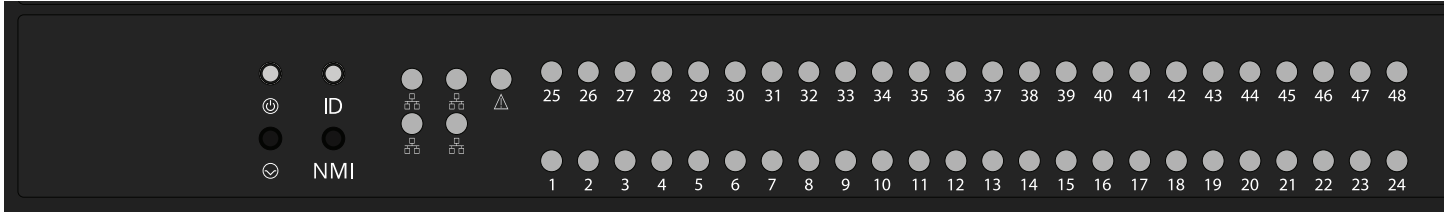
The fault indicator is on during the initial power-on self-test (POST) and turns off during normal operation. It turns on if the TrueNAS software issues an alert.



Light / Button	Function	Color and Indication
	Powers the system on/off	Blue (Solid): System Ready
	Resets the system	N/A
ID	Activates Locate ID	Blue (Flashing): Locate ID active
	N/A	Green (Flashing): Component Fault
	N/A	Amber (Flashing): Link Active
1 - 48	N/A	Blue (Solid): Drive Ready Blue (Flashing): Drive Activity

### 6.2 Drive Slot Indicators

The R50 drive slots only contain one red LED to denote drive failure.

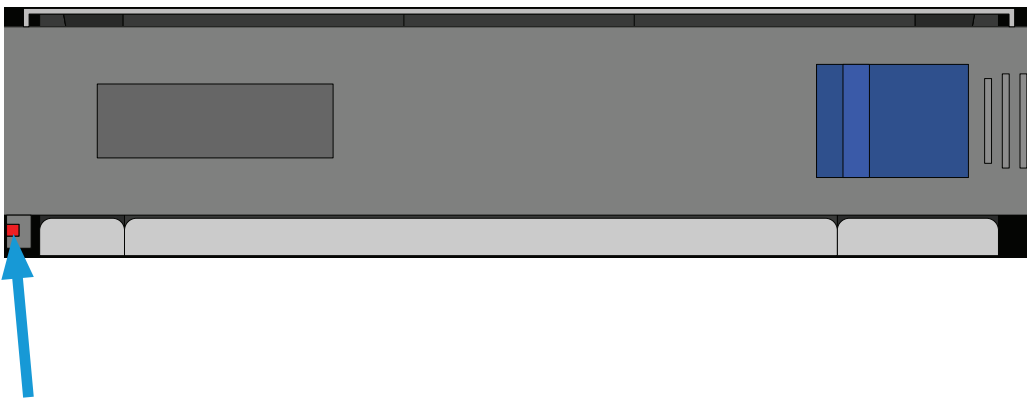

## 7 Racking Procedure

### 7.1 Install Cage Nuts

Cage nuts attach to holes in the rack posts with the nut on the inside of the rack and “wings” pointed horizontally.

Attach six cage nuts in the rack front posts, three on each side.

Place two cage nuts in the **top and middle holes of the top 1U** in the reserved 4U of rack space.

Place the third cage nut **in the middle of the bottom 1U** in the reserved 4U of rack space.

Place the remaining three cage nuts in the same points on the other front rack post.

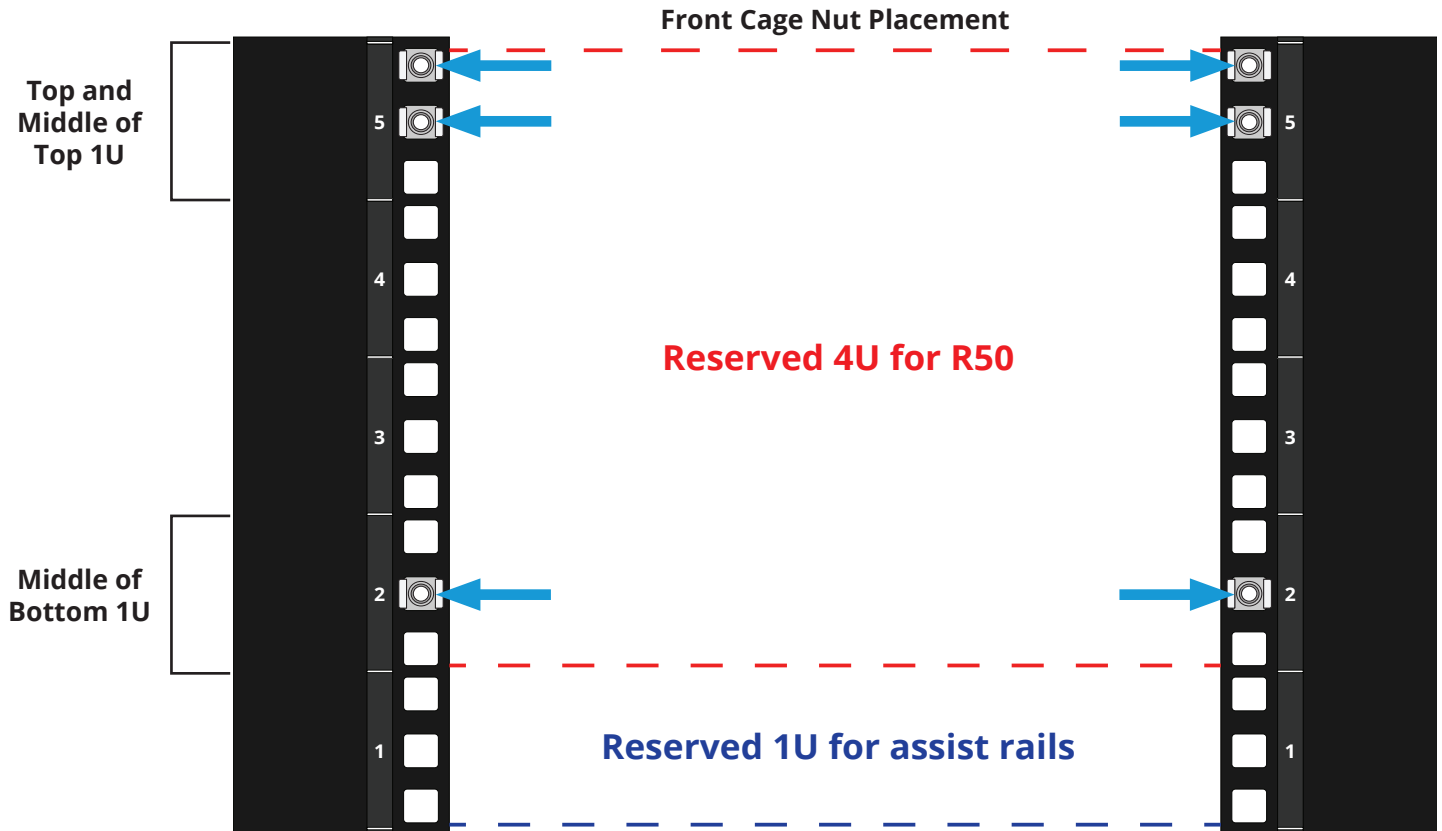

You need **four** cage nuts for each rear rack rail (**eight total**).

In the top 1U of reserved rack space, place a cage nut in the bottom attach point.

In the second 1U (below top 1U), place a cage nut in the middle attach-point.

In the third 1U (below second 1U), place cage nuts in the middle and bottom attach points.

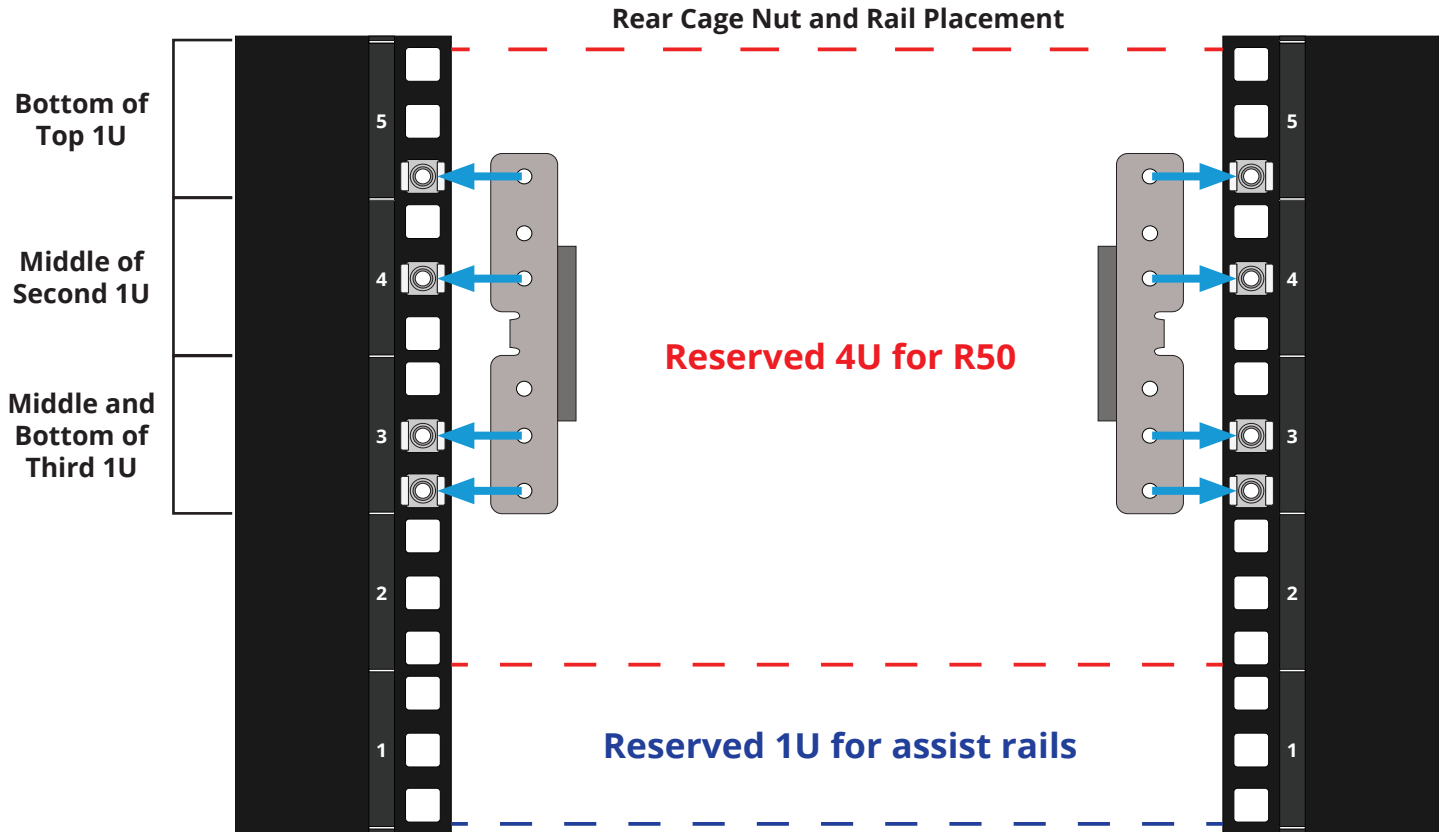

## 7.2 Install the Rack Rails

Remove the rack rails from the system.

Fit a rail over the cage nuts on one rear rack post (the tab fits into the empty slot in the bottom of the second 1U) and use four M5 × 15mm screws to secure it to the rack.

Repeat for the other rail.

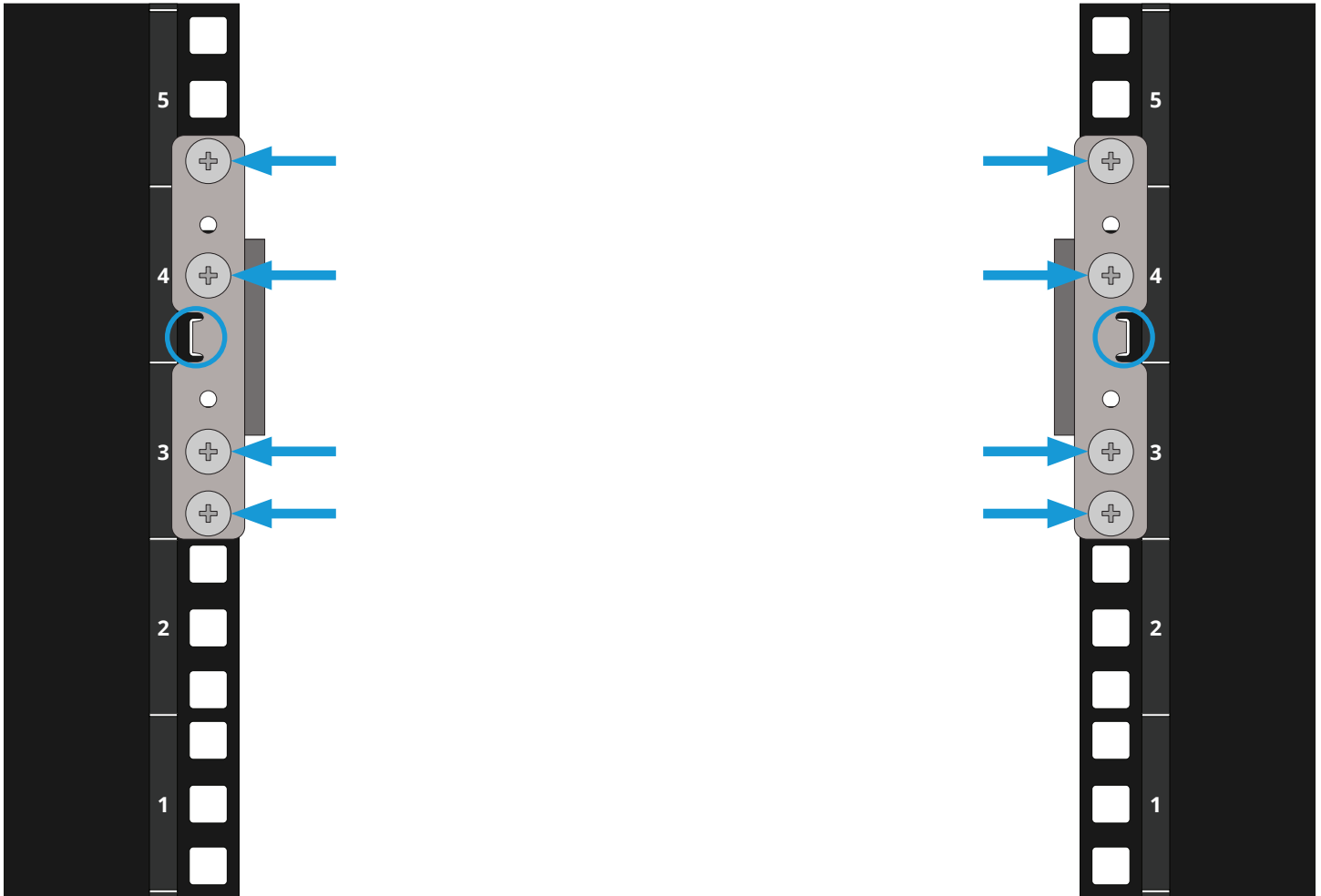

### 7.3 Adjust the Rail Sleeve

The rail sleeve uses position 2 by default. To adjust it, remove the 12 screws (yellow circles) and move the sleeve to the position that accommodates your rack depth (see table).

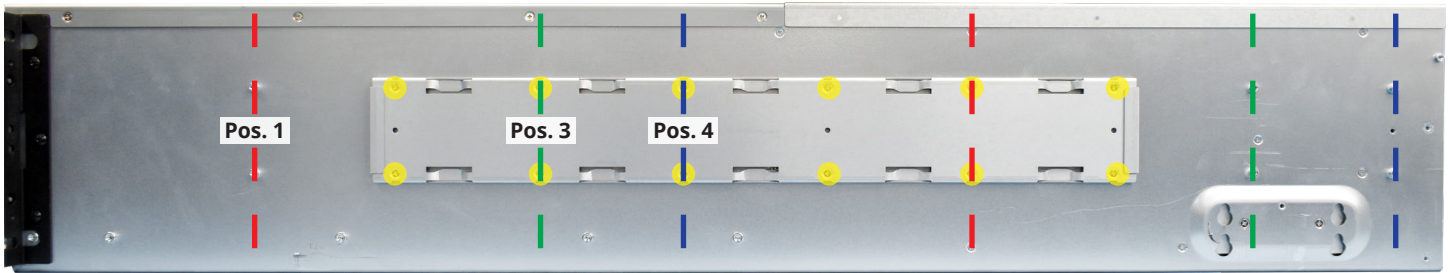

Position	Depth with Standard Ears	Depth with 40mm Extended Ears
1	27.5" - 32" (69.9 cm - 81.3 cm)	27" - 30 3/8" (68.6 cm - 77.2 cm)
2 (shown )	28 13/16" - 35 11/16" (73.2 cm - 90.6 cm)	27.5" - 34 1/8" (69.9 cm - 86.7 cm)
3	32.5" - 43 1/8" (82.6 cm - 109.5 cm)	30 15/16" - 37.5" (78.6 cm - 95.3 cm)
4	36 1/4" - 43 1/8" (92.1 cm - 109.5 cm)	34 5/8" - 41.5" (87.9 cm - 105.4 cm)

## 7.4 Install the Assist Rails

At the front rack post, install an assist rail front tab into the middle space of the bottom 1U reserved for assist rails, then install two of the M5 × 10mm screws to secure it to the front rack post.

Extend the assist rail to the rear rack post and use two more screws to secure it.

Tighten the four bolts inside the assist rail to set the length.

Repeat for the other rail.

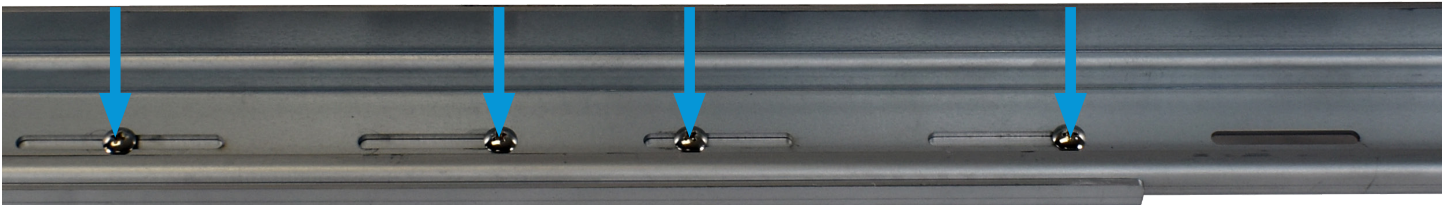

## 7.5 Mount the R50 in the Rack

Two people should lift the R50. Set the system onto the assist rails and align the rail sleeves with the rails. Slide the system forward until it is flush with the front of the rack.

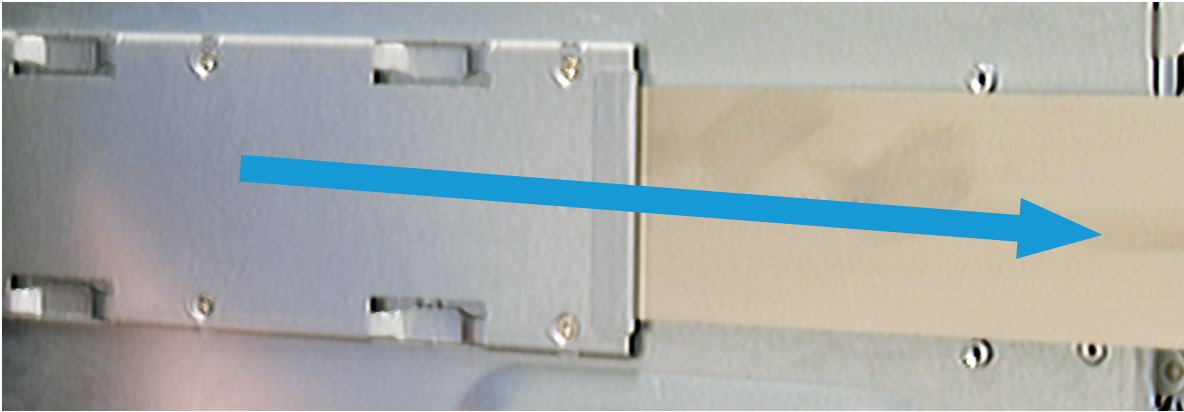

### ⚠ Warning - Pinch Point

The R50 can pinch or crush fingers when sliding the rail sleeves onto the rack rails.

## 7.6 Attach the Extended Ear Brackets (Optional)

The 3rd gen R50 is longer than previous models, so it ships with extended ear brackets to secure it in short racks.

If your rack is too short, remove the five screws (two on the front, three on the side) holding each ear bracket on the R50. Remove both ear brackets from the chassis and replace them with the extended ear brackets.

Secure the extended ear brackets to the chassis using the same five screws the standard ear brackets used.

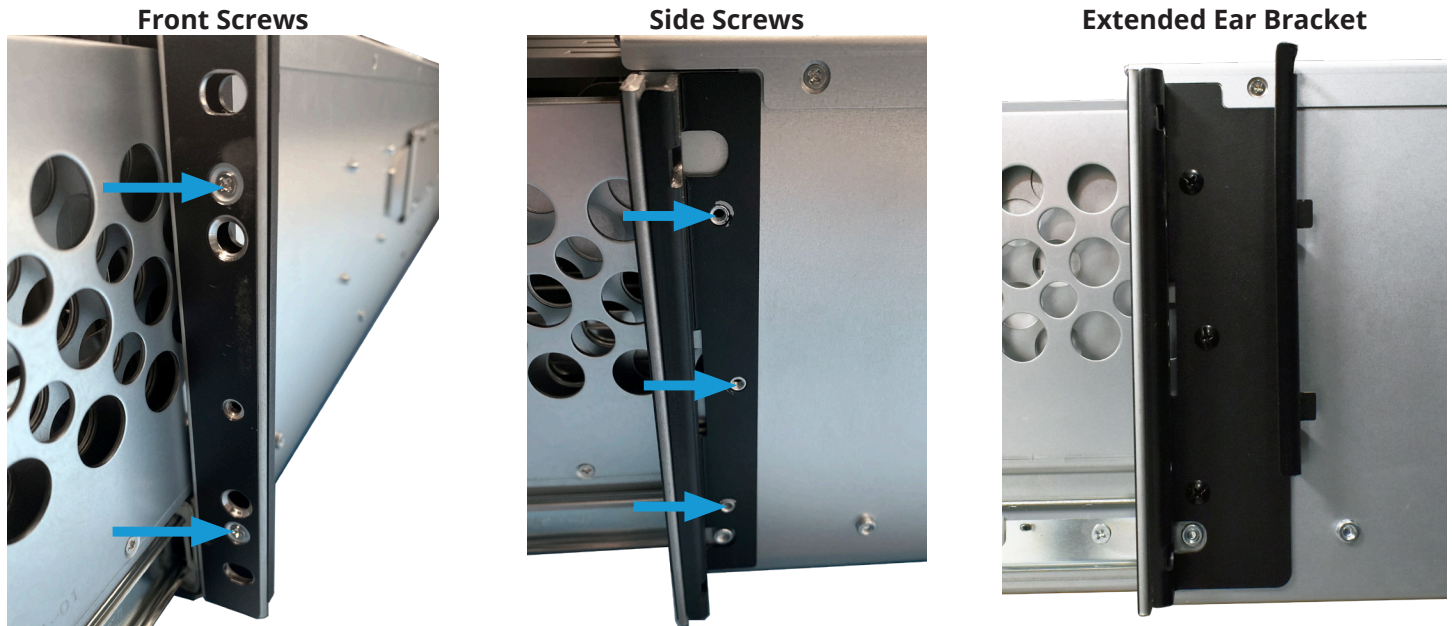

Use four M5 × 20mm screws to secure each chassis ear bracket to the rack.

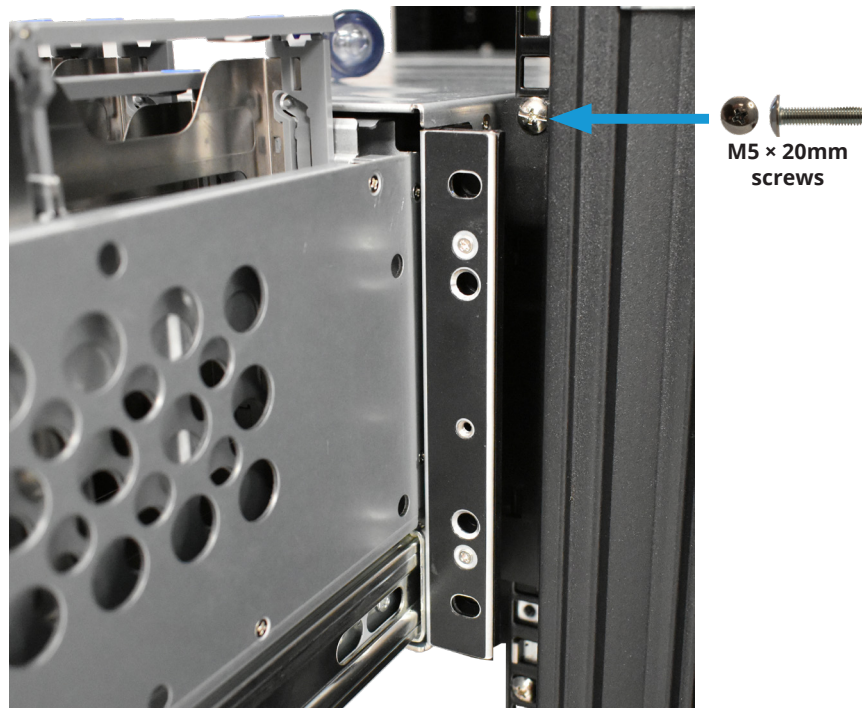

Once you mount the system in the rack, uninstall the assist rails from the rack.

## 8 Managing Drives

The R50 drive drawer sits on internal rails and slides out of the system. Hard drives install into the drawer without drive trays. The NVMe drives are on the back of the system, and use removable trays to mount drives in the system.

### 8.1 Open the Drive Drawer

Unlock the front and loosen the captive thumbscrews, then use the handles to pull the drawer out.

#### ⓘ Important - Overheat Risk

To prevent overheating, do not open the drawer for more than 1 minute with the system running.

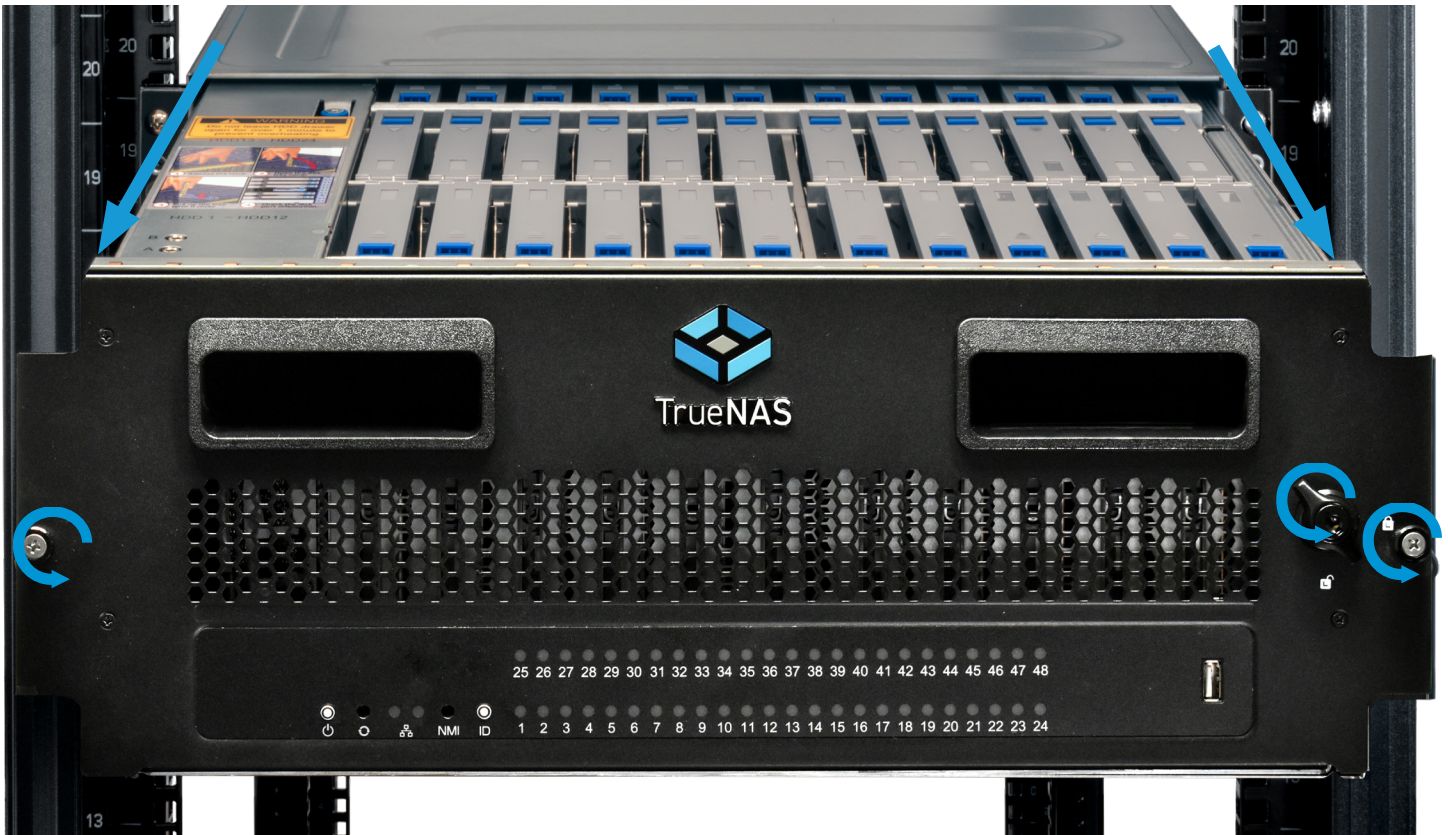

## 8.2 Install Hard Drives

Push the blue release tab on a slot cover and lift. Gently grasp the inner tray and pull it up until it locks into place.

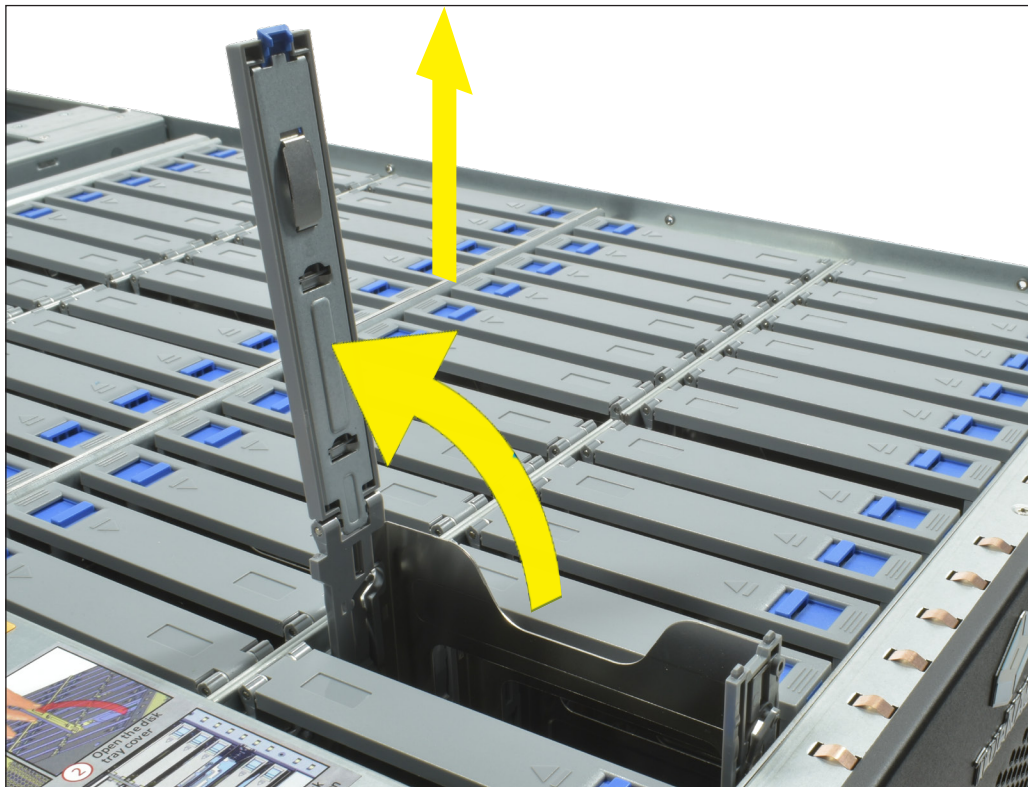

The R50 is certified to use WD Helium drives only.

Align a hard drive with the connectors facing downwards into the system, then slide the drive into the slot.

Squeeze the plastic release tabs on each side of the tray, then push the tray downwards to install the hard drive into the system.

Close the slot cover and make sure it locks, then repeat for all remaining drives.



### 8.3 Close the Drive Drawer

Pull the blue release catches on each rail toward you, then push the drawer into the system.



To secure the drive bay and prevent it from accidentally opening, tighten the captive thumbscrews on the front of the system.

You can also use the included key to lock the drive drawer and prevent unauthorized access.

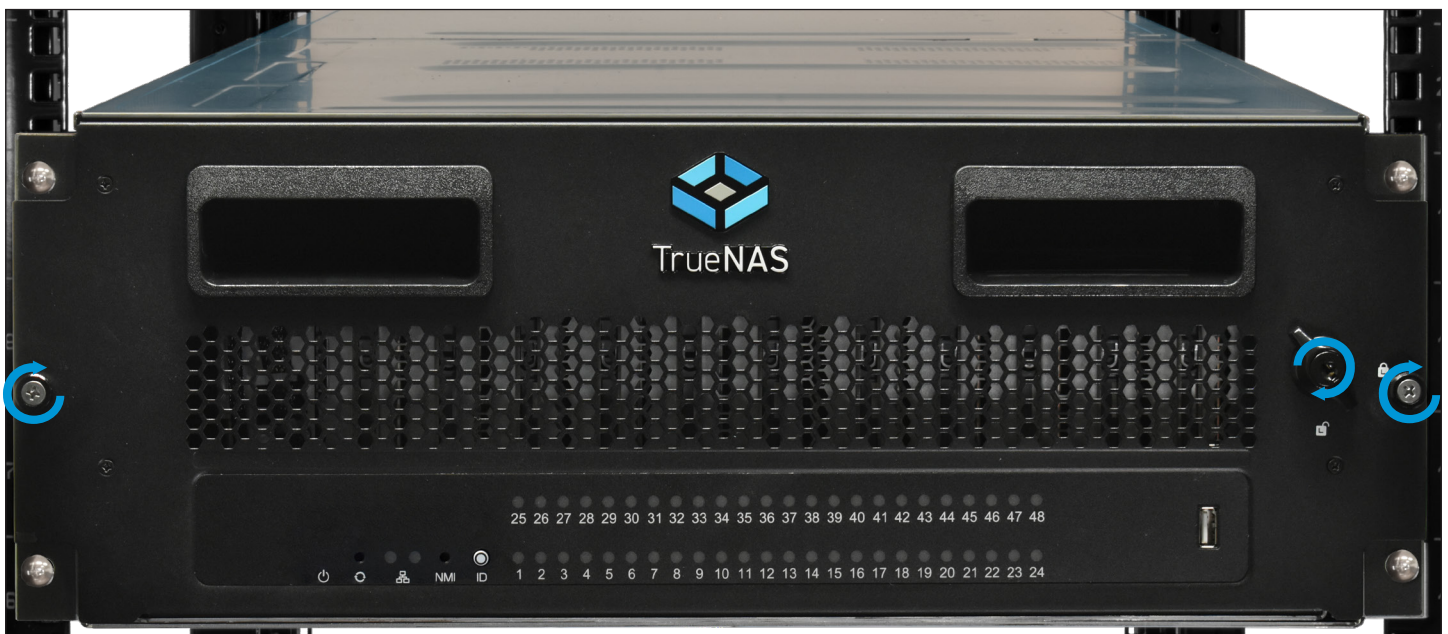

## 9 Install Cables

Connect one ethernet network cable from your local switch or management network to the Out-of-Band Management (OOBM) port, and another one to the first 1GbE ports (port 1) **on both controllers**.

Next, connect a monitor and keyboard to the VGA and USB ports on the same controller.

Finally, connect the power cables **to both power supplies**, then plug them into a power distribution unit.

### ⚠ Warning - Grounded Connection

Always connect power cords to properly grounded connections.

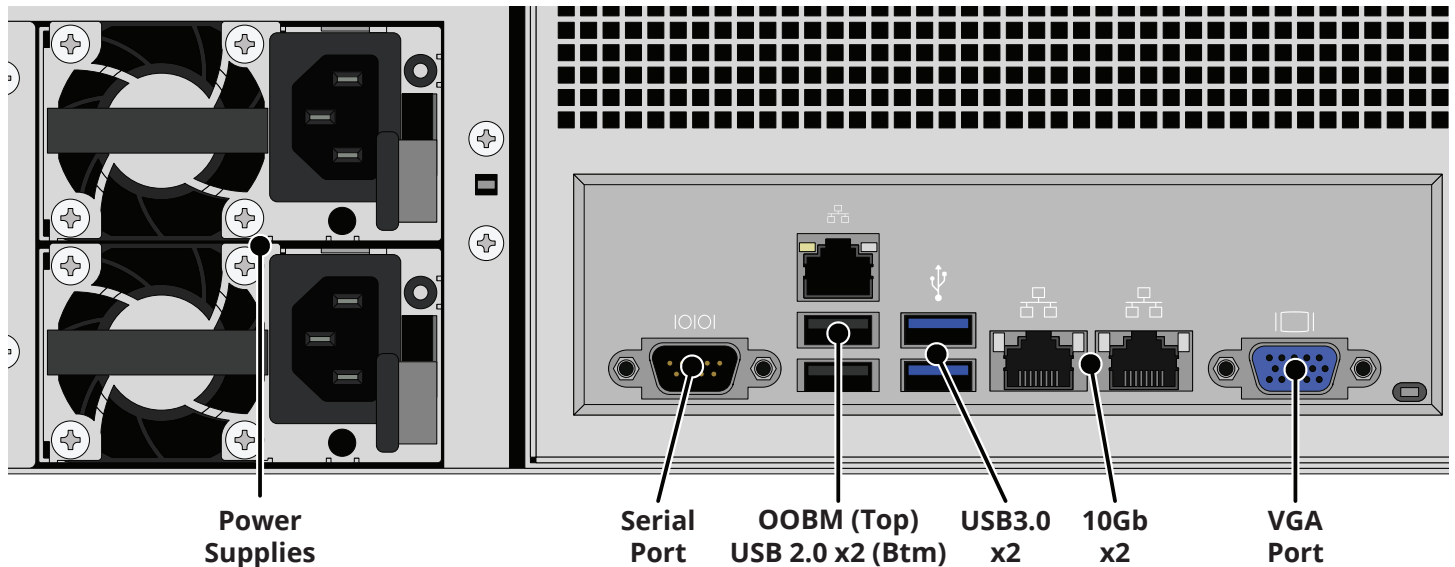

### ⚠ Warning - BIOS and IPMI Firmware

Your system is equipped with the optimal BIOS and IPMI firmware out of the box.

**DO NOT UPGRADE** your system's BIOS and IPMI firmware.

We recommend that IPMI be on a separate and secure network without Internet access.

Please contact support if you need to upgrade your system's BIOS or IPMI firmware.

## 9.1 10/40/100GbE NIC Cabling

If you ordered your system with a 10, 40, or 100GbE NIC, you can connect the SR4 cables now.

Insert SR4 optics into the bottom port with the gold connectors facing left, then plug the SR cable into the optics.

Repeat for the other port.

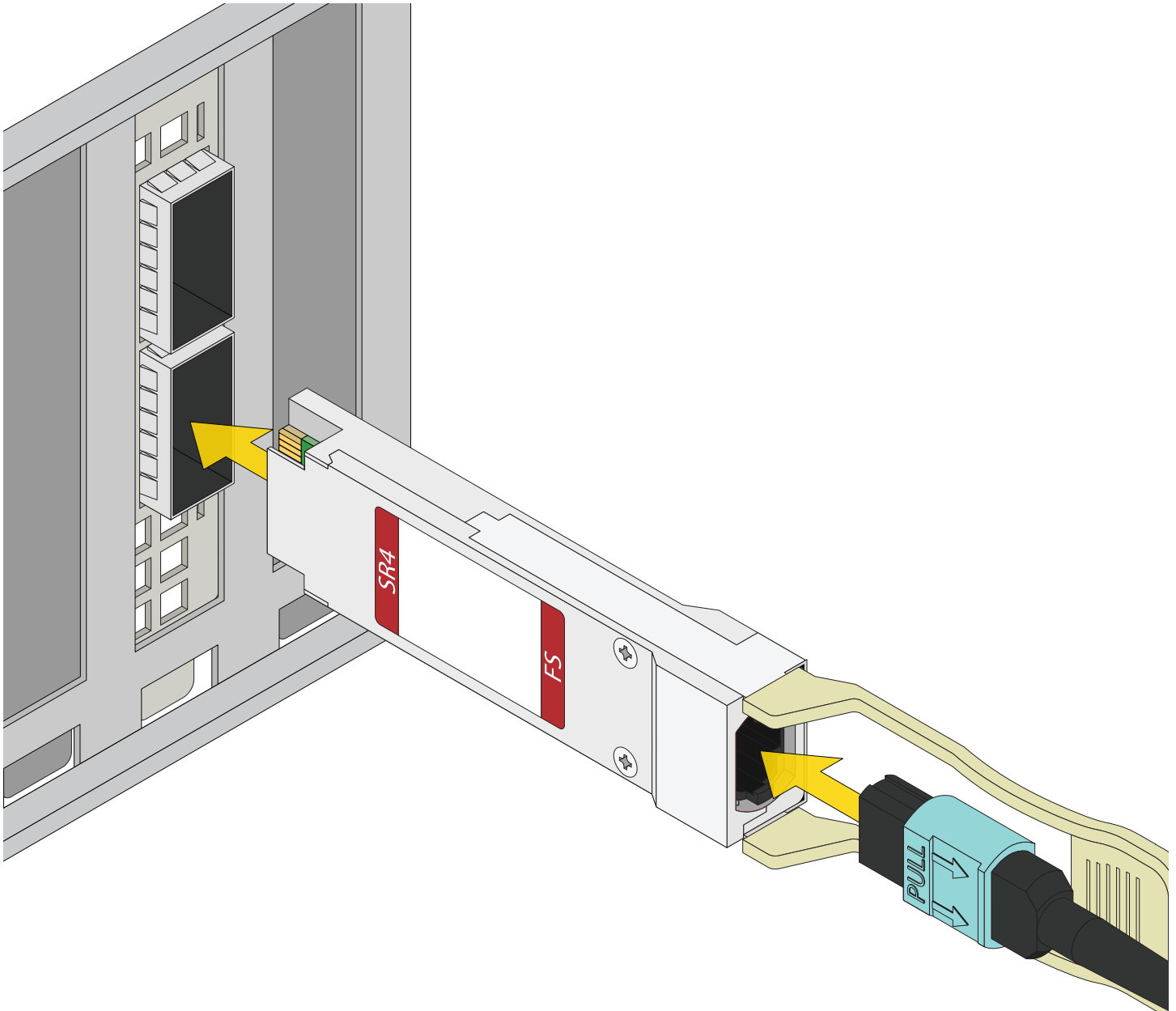

## 9.2 1/10/25GbE or Fibre Channel NIC Cabling

If you ordered your system with a 1, 10, or 25GbE NIC, or a Fibre Channel NIC, you can connect the SR cables now.

Insert SR optics into the bottom port with the gold connectors facing left, then plug the SR cable into the optics.

Repeat for the other port.

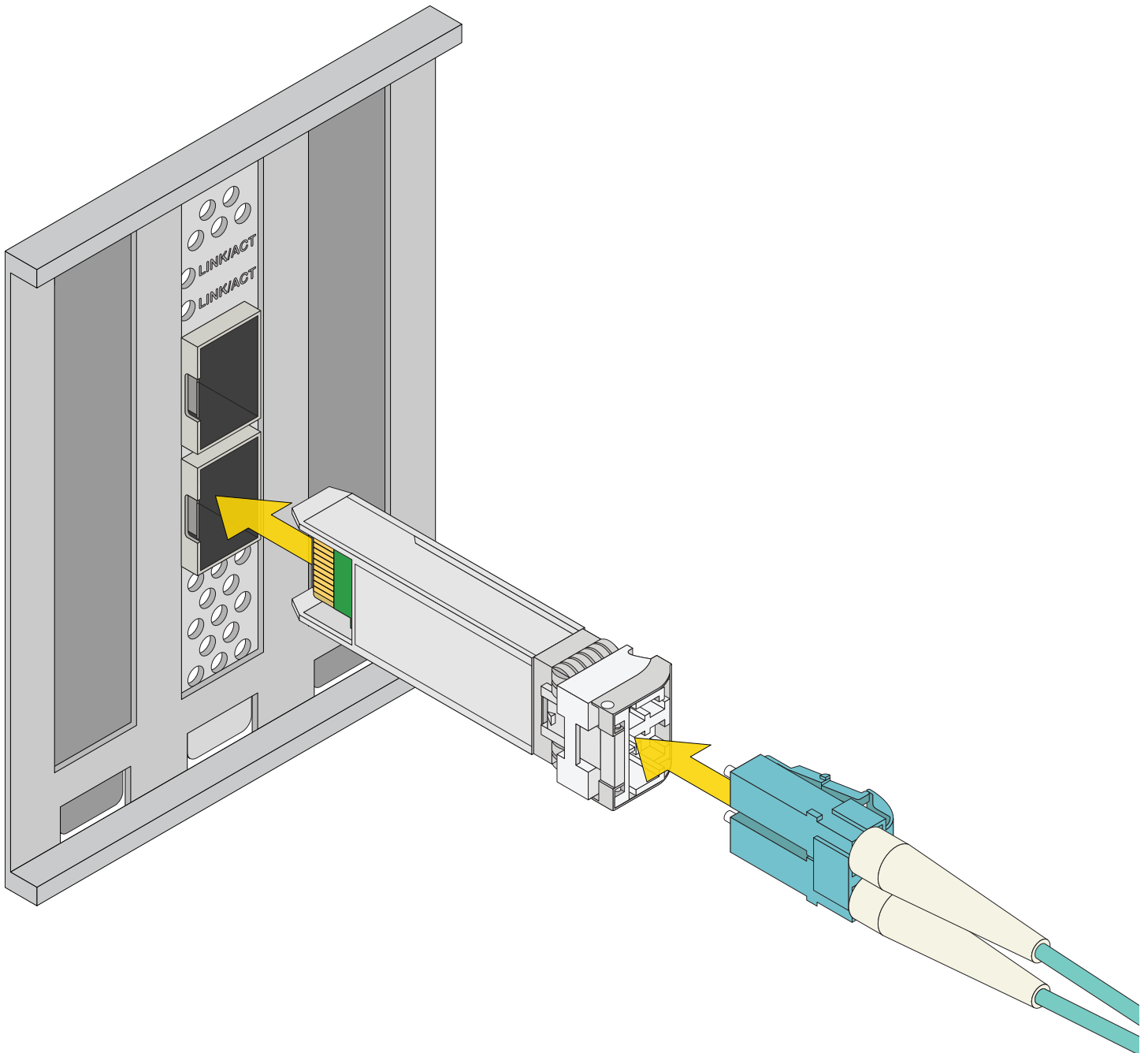

### 9.3 Expansion Cabling

If you ordered your system with an expansion shelf, you can set up the SAS3 cables now.

Insert a SAS cable into the bottom SAS port with the blue tab facing left, then insert the other end into the first expansion shelf IOM/expander.

If you have a second expansion shelf, insert a SAS cable into the next R50 SAS port with the blue tab facing left, then insert the other end into the first expansion shelf IOM/expander on the second shelf.

Refer to the SAS Connections section or refer to your expansion shelf documentation for connection diagrams.

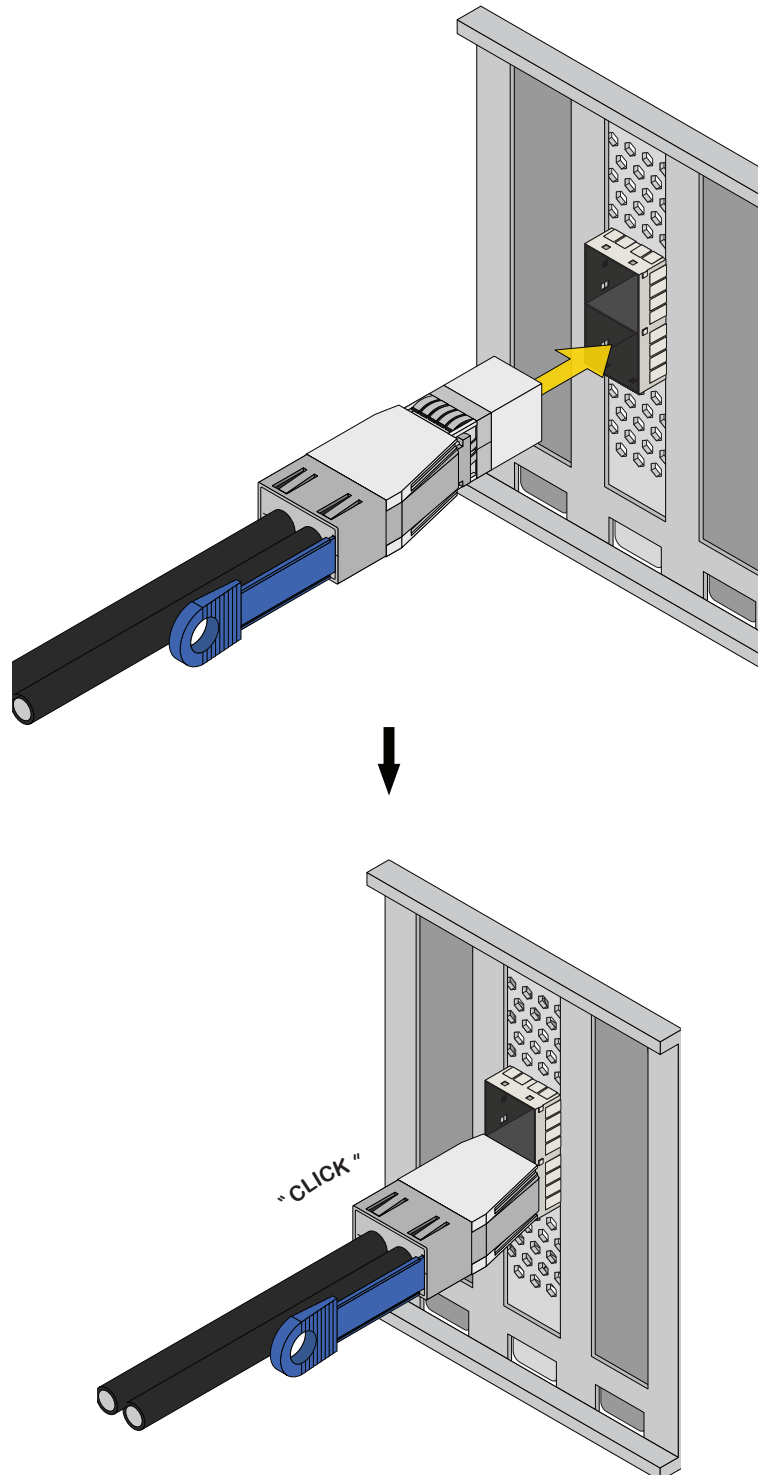

## 10 Boot the System

After plugging the power cables into outlets, the system powers on and boots into TrueNAS.

When booted, the system console displays the TrueNAS web UI IP address, which is either preconfigured according to customer guidelines or automatically generated with DHCP.

Enter the IP address into a browser on a computer on the same network to access the web user interface.

See your welcome email or the password stickers on each controller at the rear of the unit for login credentials.

# 11 Storage Expansion

## ⓘ Important - SAS Configuration

When setting up SAS connections, please adhere to the wiring example below. Connecting Expansion Shelves incorrectly causes errors. Never cable a single controller to different IOMs/expanders on the same shelf.

### 11.1 ES24

R50 with a single ES24 Expansion Shelf

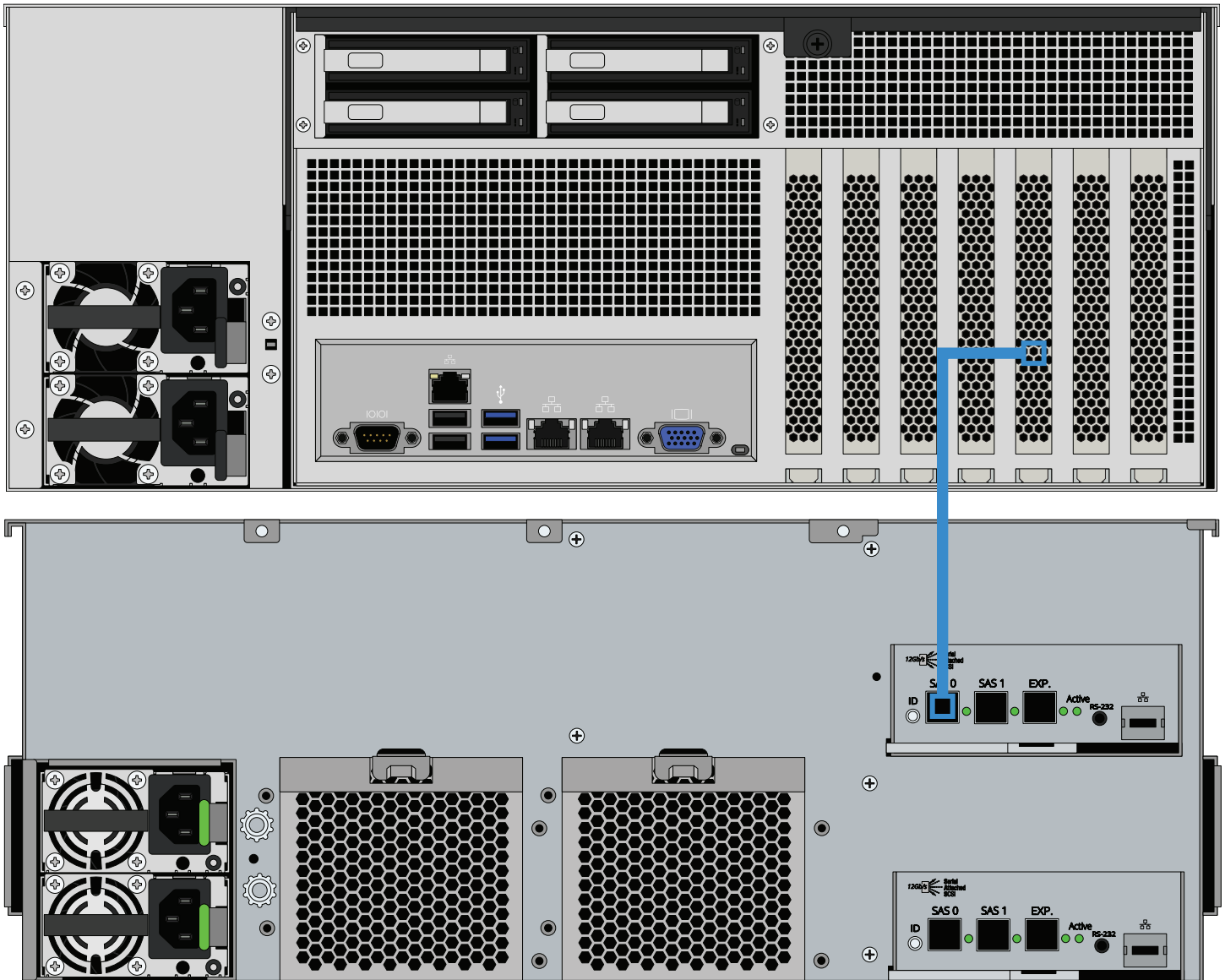

# R50 with two ES24 Expansion Shelves

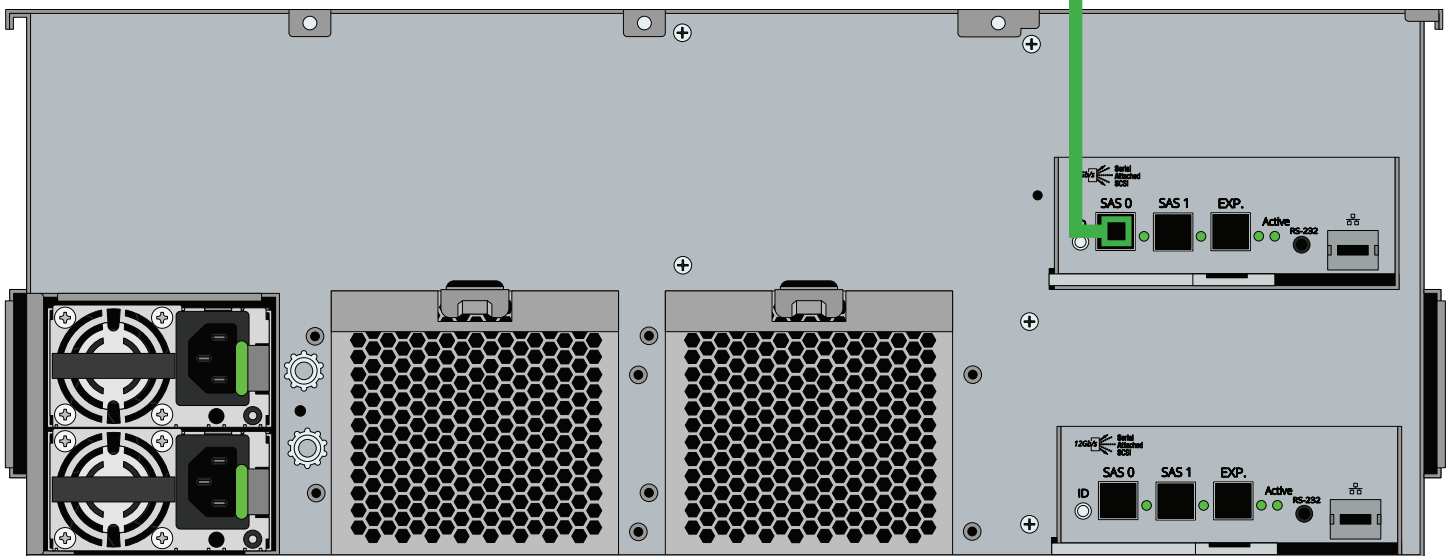
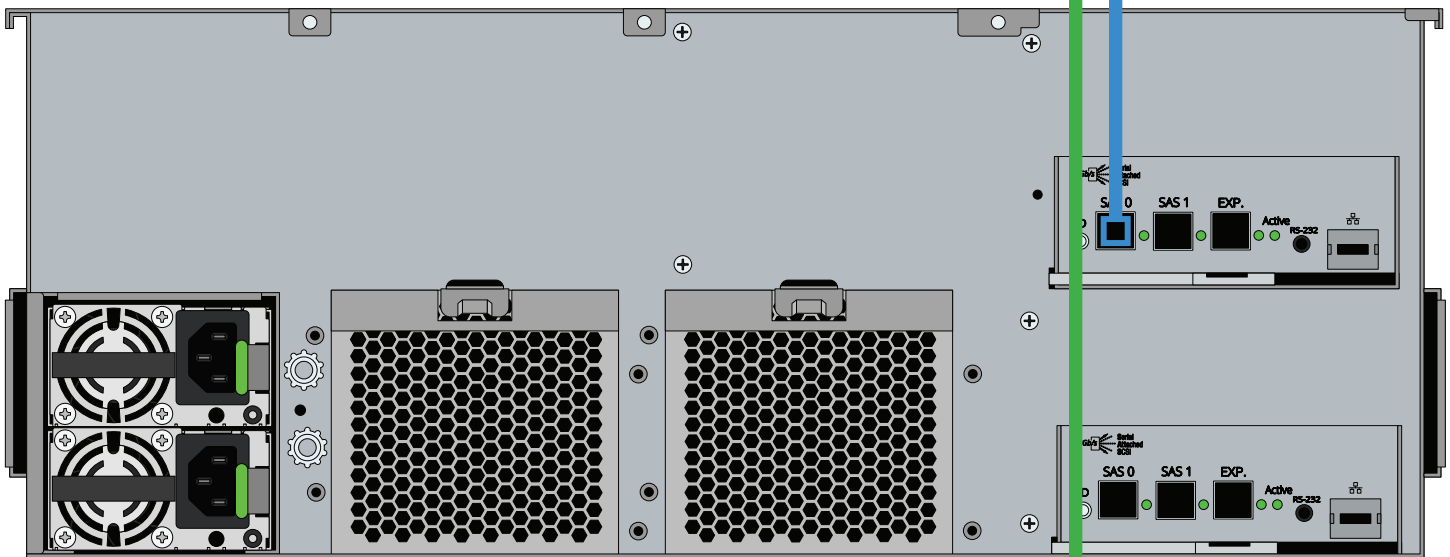
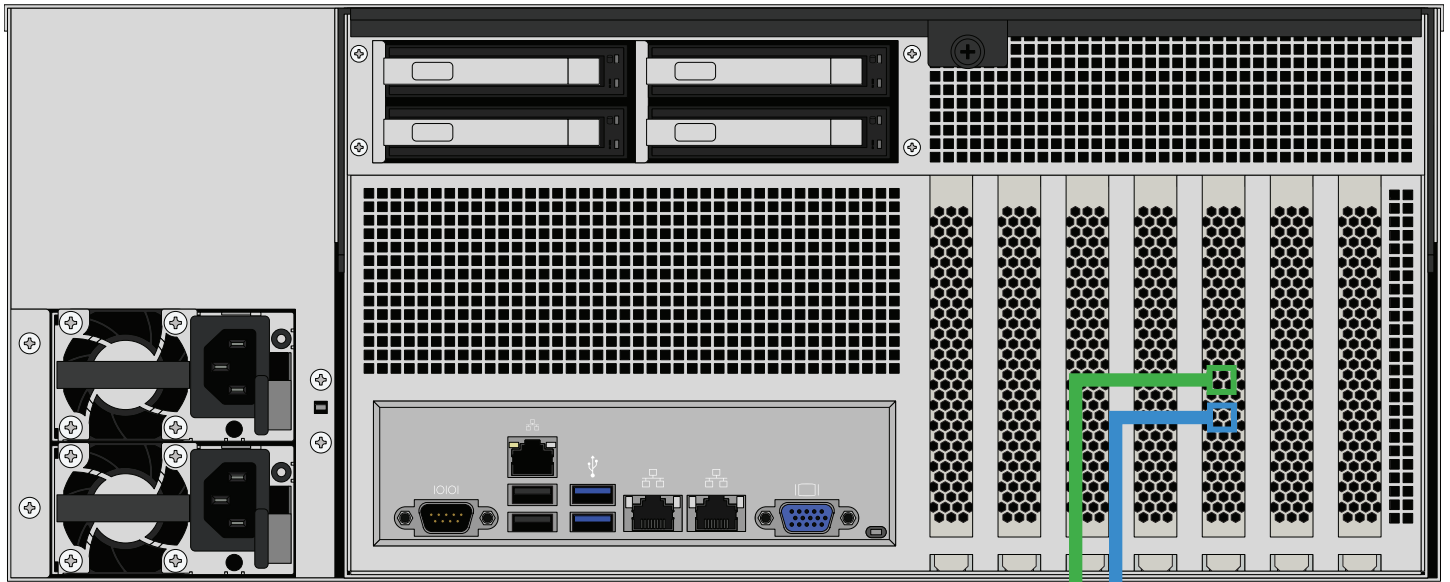

## 11.2 ES24F

R50 connected to one ES24F shelf.

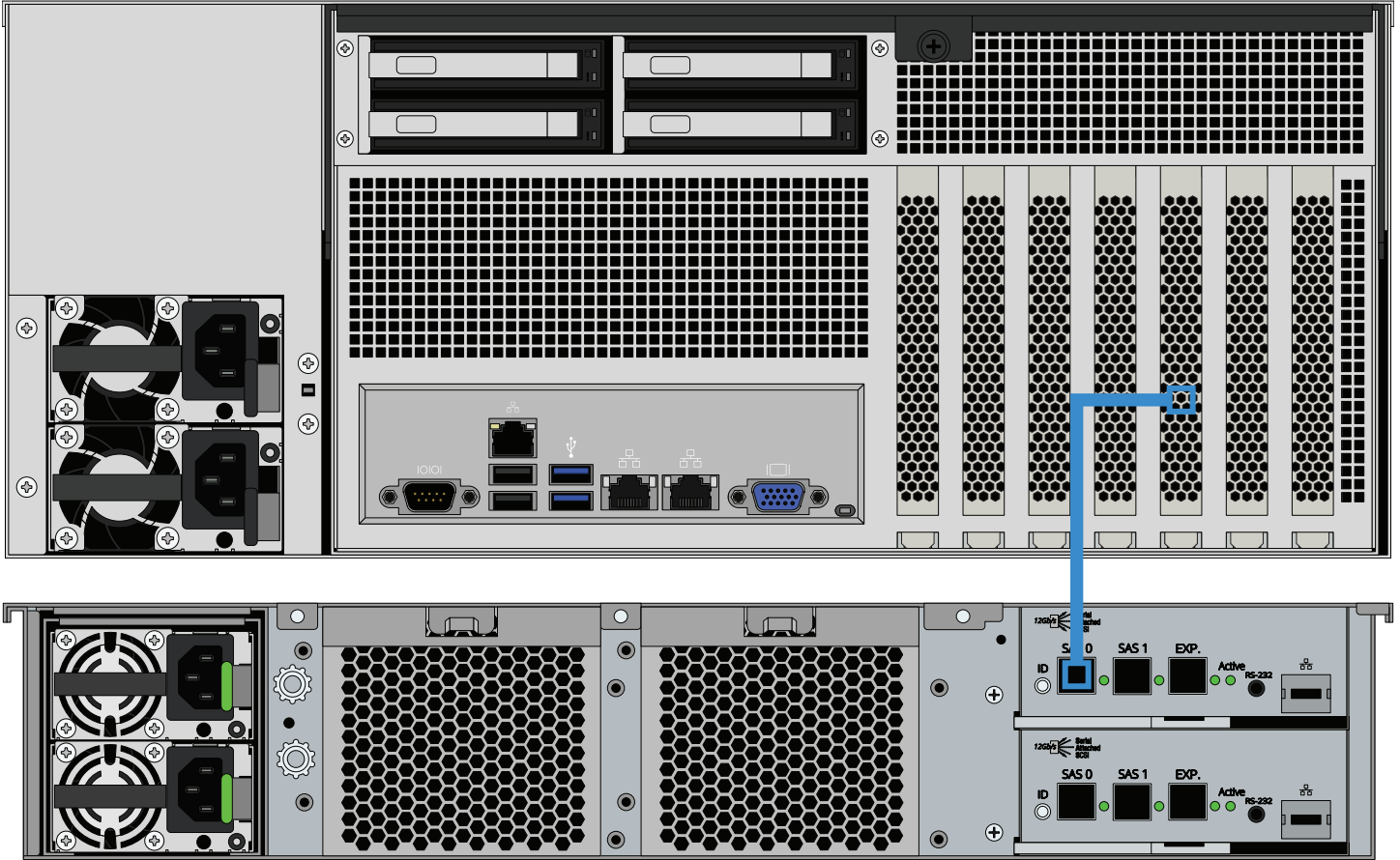

R50 with two ES24F Expansion Shelves

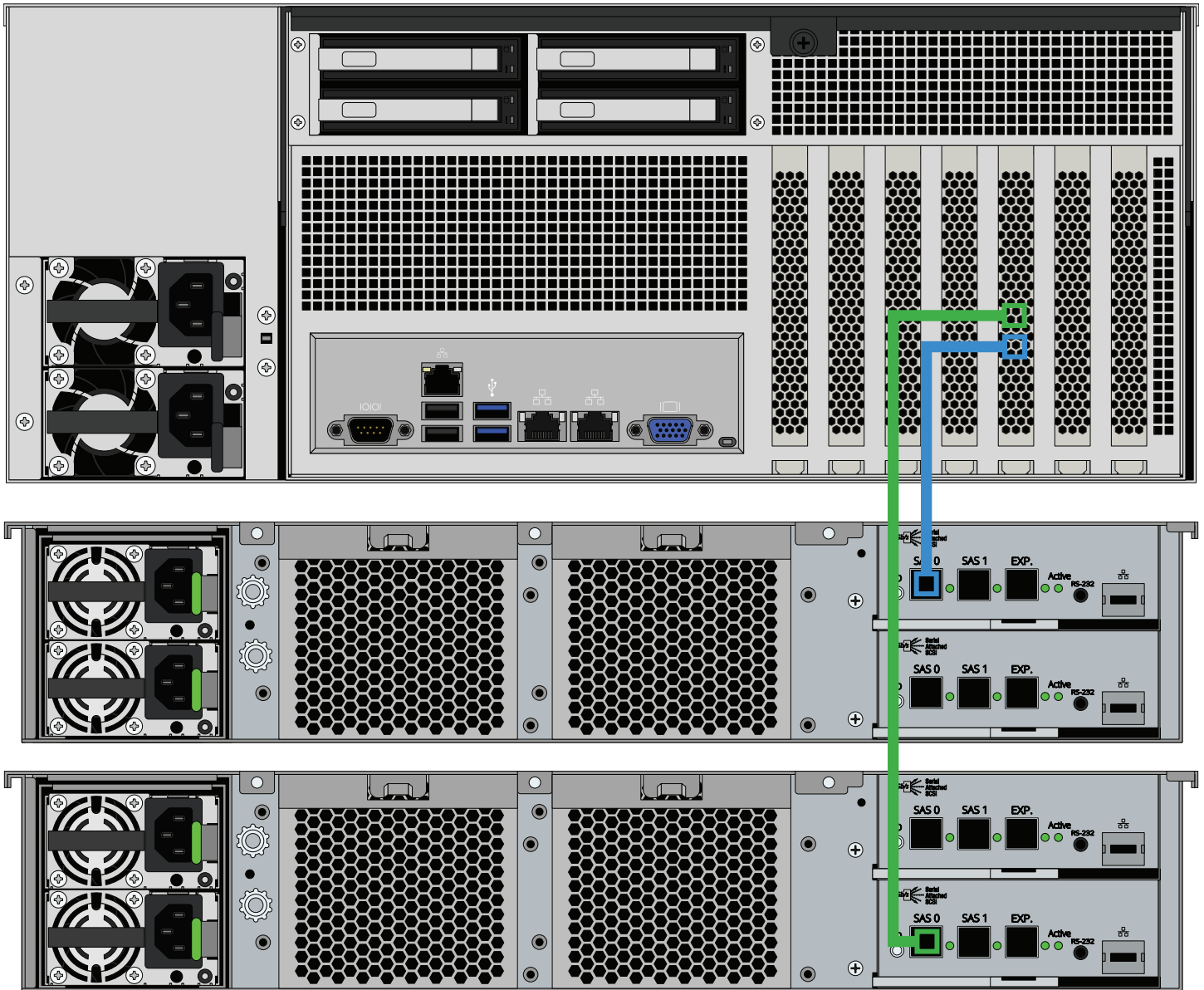

### 11.3 ES102 Gen 1 and ES60 Gen 2

R50 with a single ES102 Gen 1 or ES60 Gen 2 Expansion Shelf

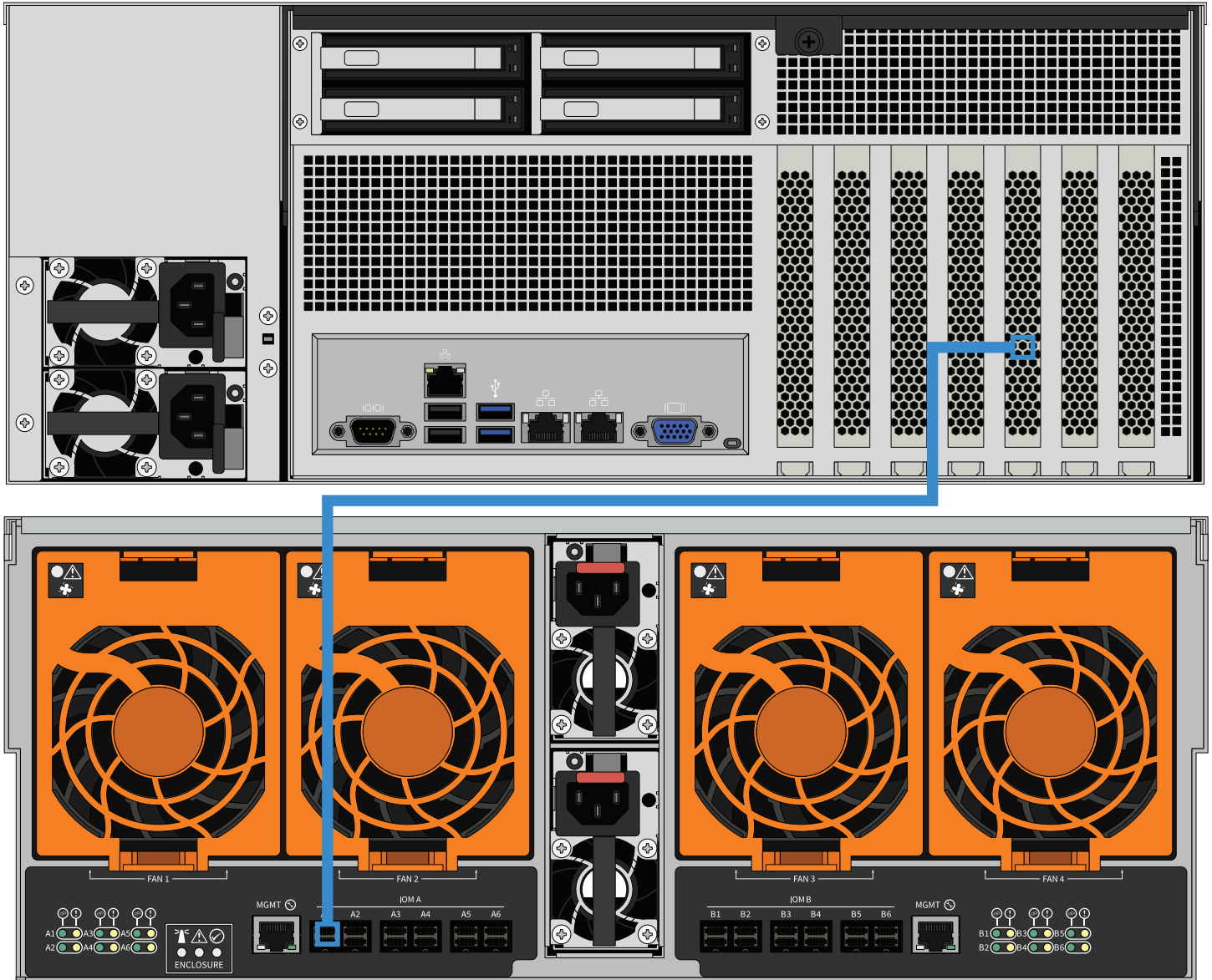

R50 with two ES102 Gen 1 or ES60 Gen 2 Expansion Shelves

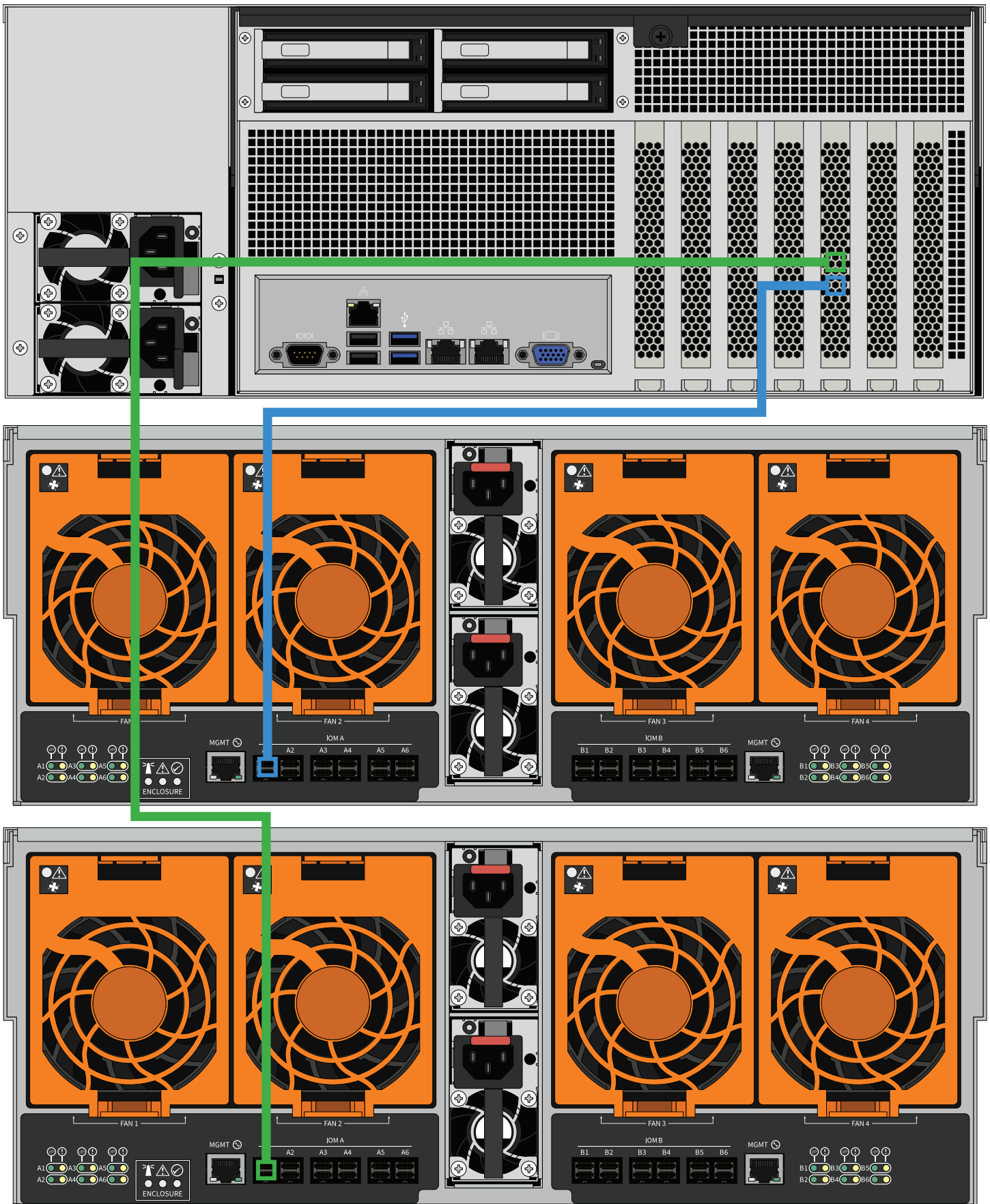

## 11.4 ES102 Gen 2

R50 with a single ES102 Gen 2 Expansion Shelf

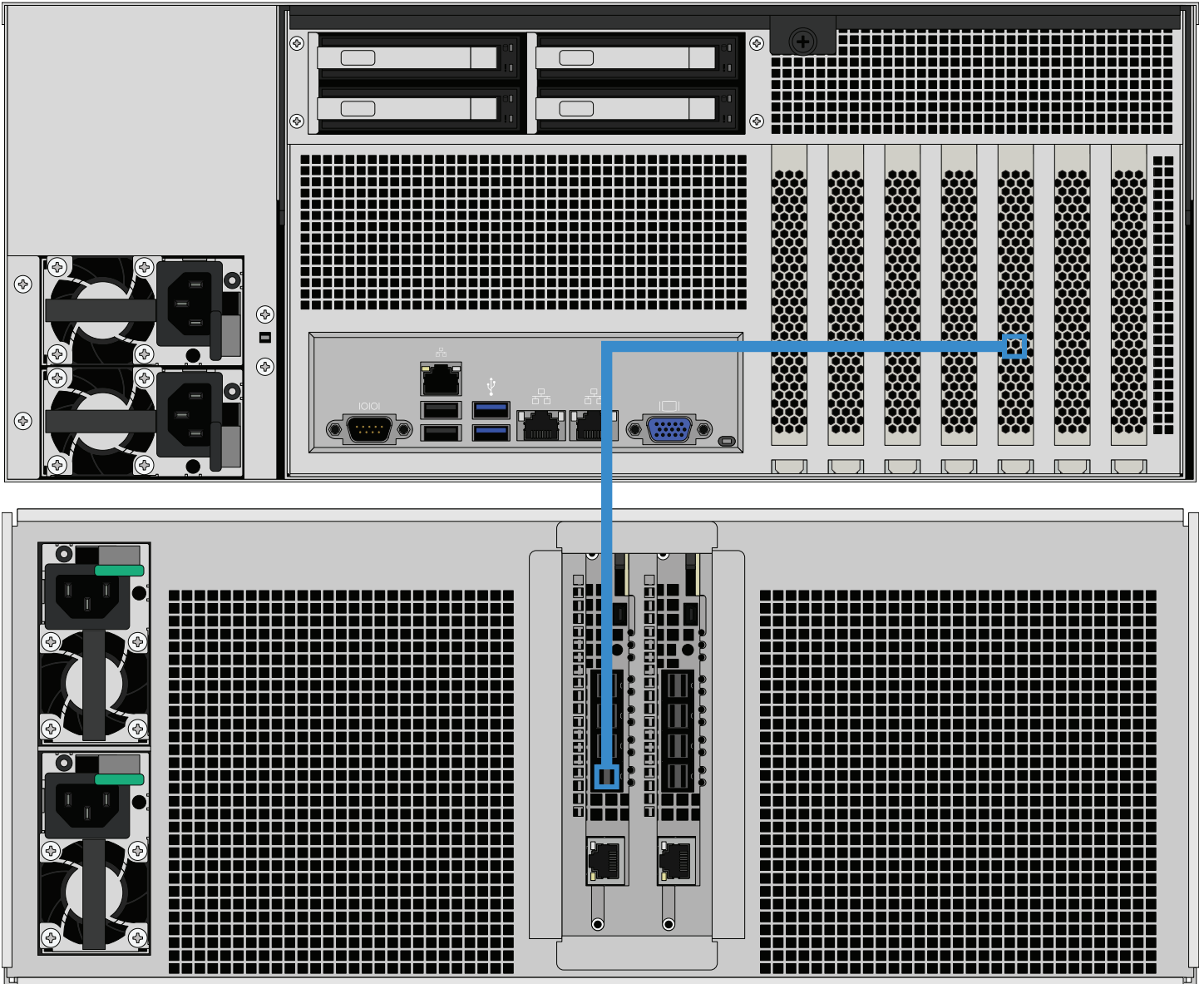

R50 with a single ES102 Gen 2 Expansion Shelf

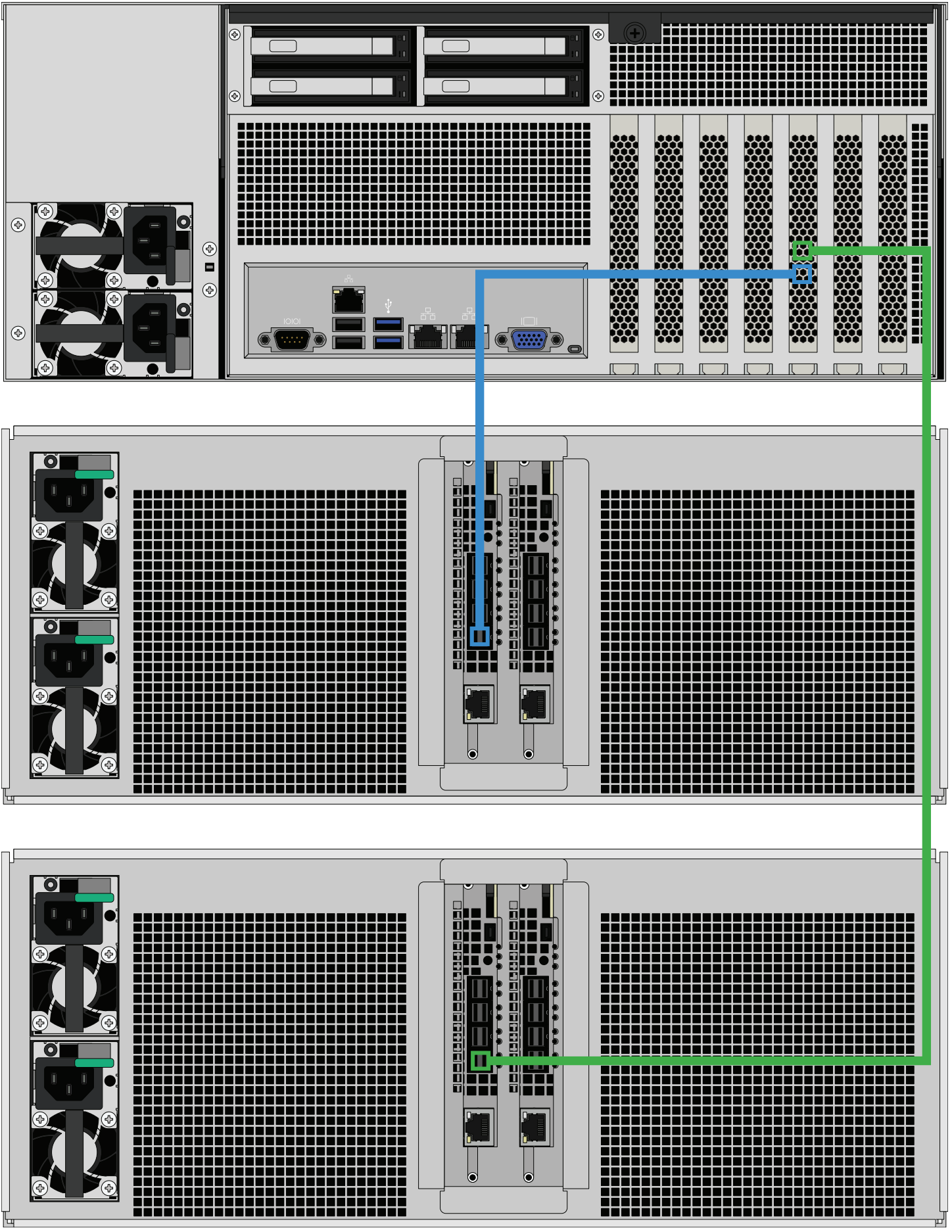

## 12 Unracking Procedure

### 12.1 Uninstall Cables

Disconnect both power cables from the PSUs, then disconnect all USB and networking cables.

### 12.2 Open the Drive Drawer

To open the drive bay, loosen the captive thumbscrews on the front of the system and unlock the drive drawer.

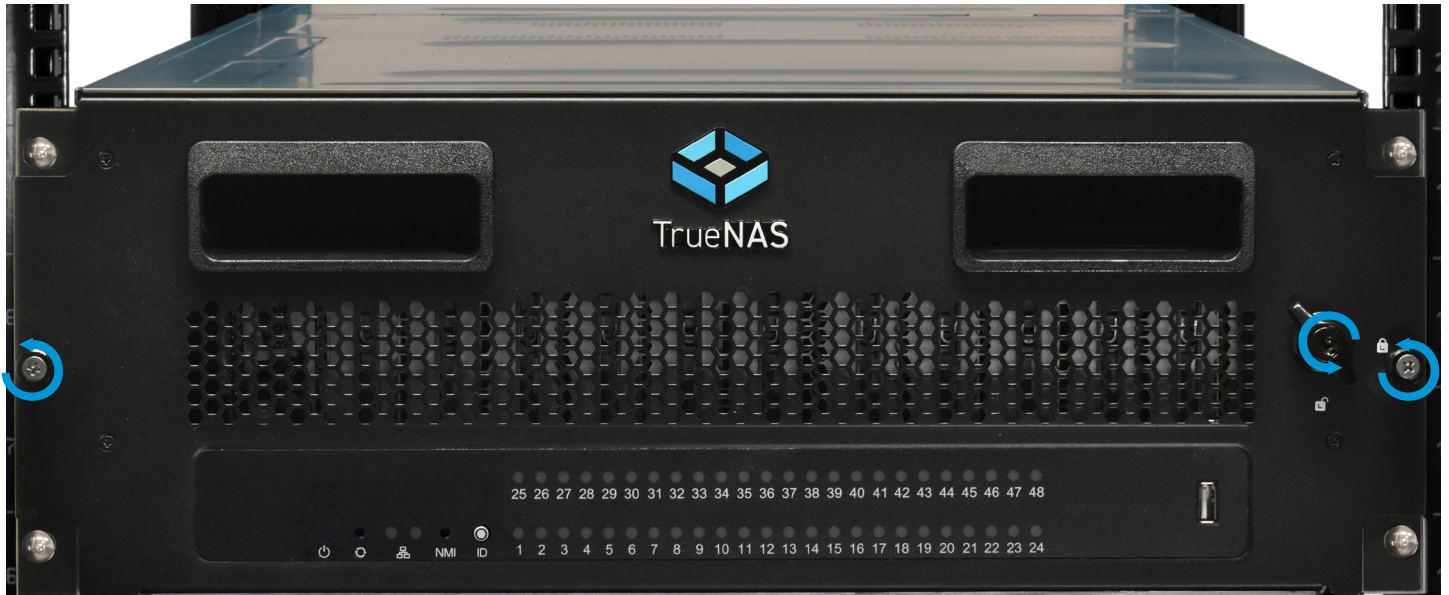

Pull the blue release catches on each rail toward you, then pull the drawer out of the system.

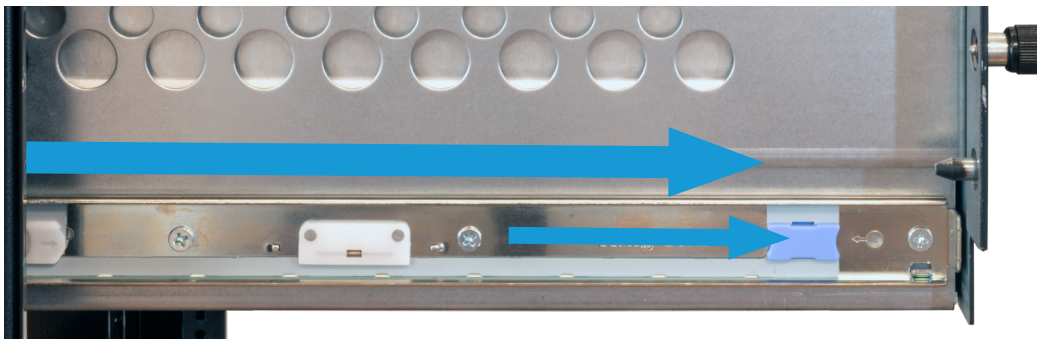

## 12.3 Remove Hard Drives

Squeeze the plastic release tabs on each side of the tray, then pull the tray upwards to remove the hard drive from the system. Close the slot cover and make sure it locks.



## 12.4 Close the Drive Drawer

Push the drawer into the chassis. Then, lock the front and tighten the captive thumbscrews.

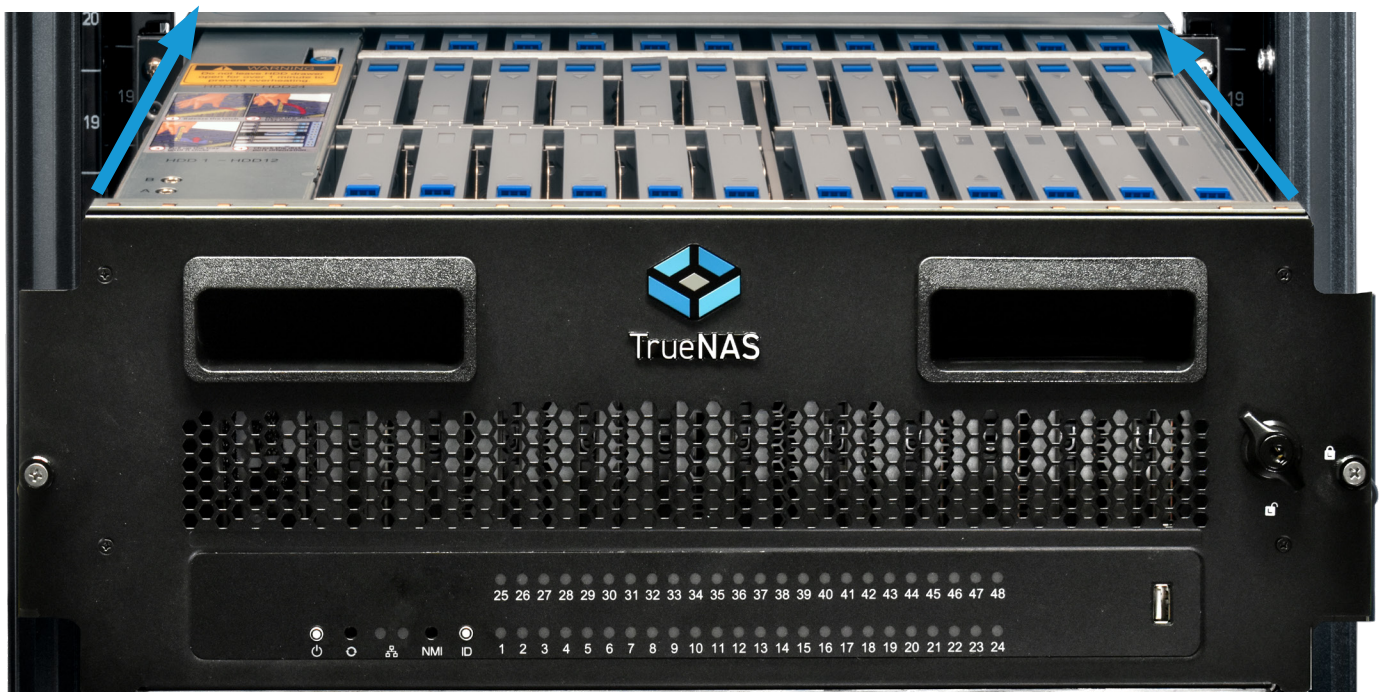

## 12.5 Remove the Extended Ear Brackets (Optional)

Remove the M5 × 20mm screws that secure each chassis ear bracket to rack.

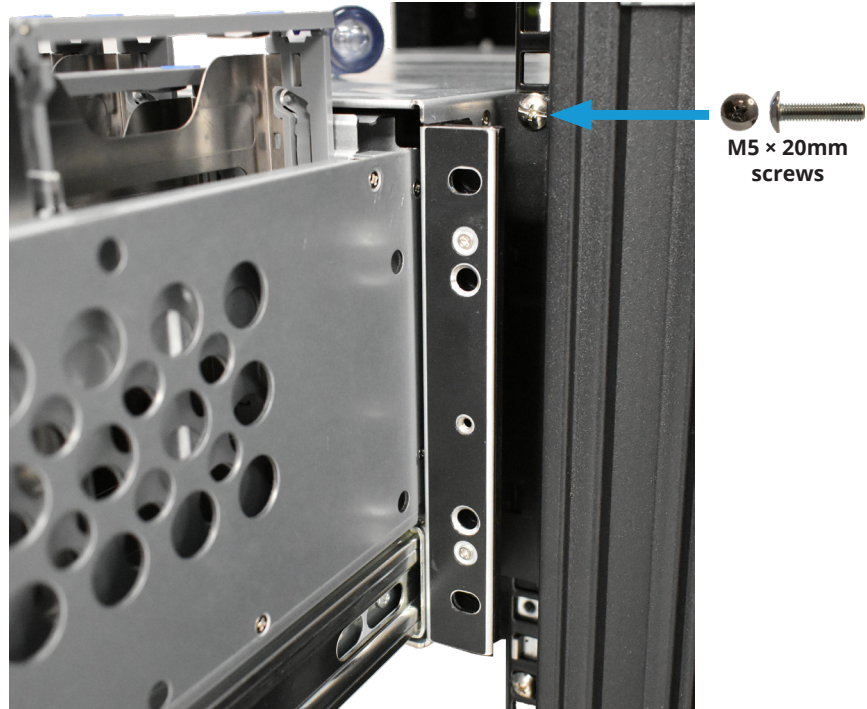

Remove the extended ear brackets from the chassis by removing all five screws.

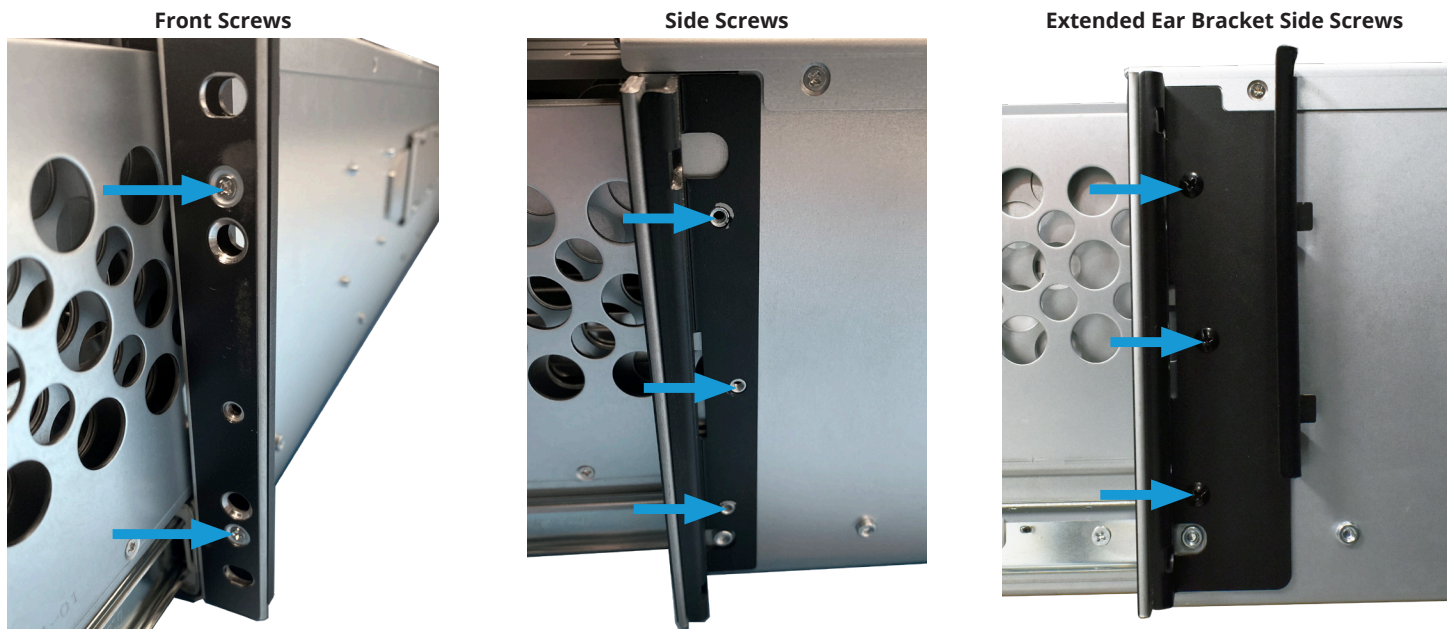

## 12.6 Unmount the R50 from the Rack

Remove the system from the rack.

### ⚠ Warning - Team Lift

The R50 requires two people to lift safely. Failure to follow safety recommendations can lead to severe system damage or personal injury.

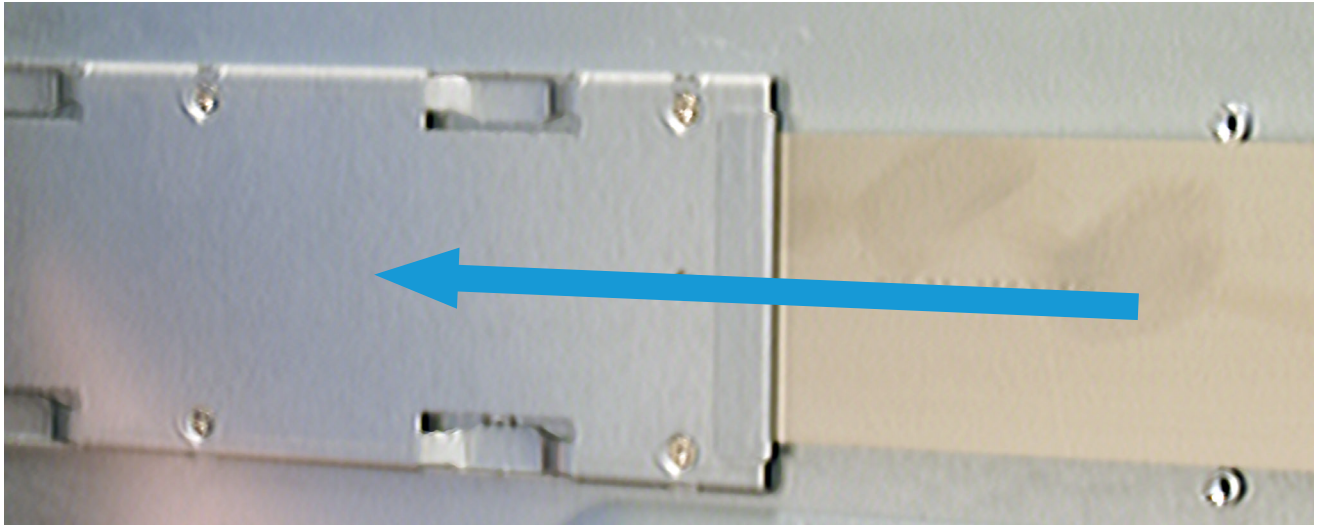

### ⚠ Warning - Pinch Point

The R50 can pinch or crush fingers when sliding the rail sleeves off of the rack rails.

## 12.7 Uninstall the Assist Rails

If the assist rails are installed, remove the two **M5 × 10mm screws** used to secure the rails to the front rack posts. Loosen the four inner screws, then compress the assist rail toward the rear rack post. Remove the two **M5 × 10mm screws** from the rear rack post. Repeat for the other assist rail.



## 12.8 Uninstall the Rack Rails

Remove the four M5 × 15mm screws used to secure the rack rail to the rack. Repeat for the other rail.

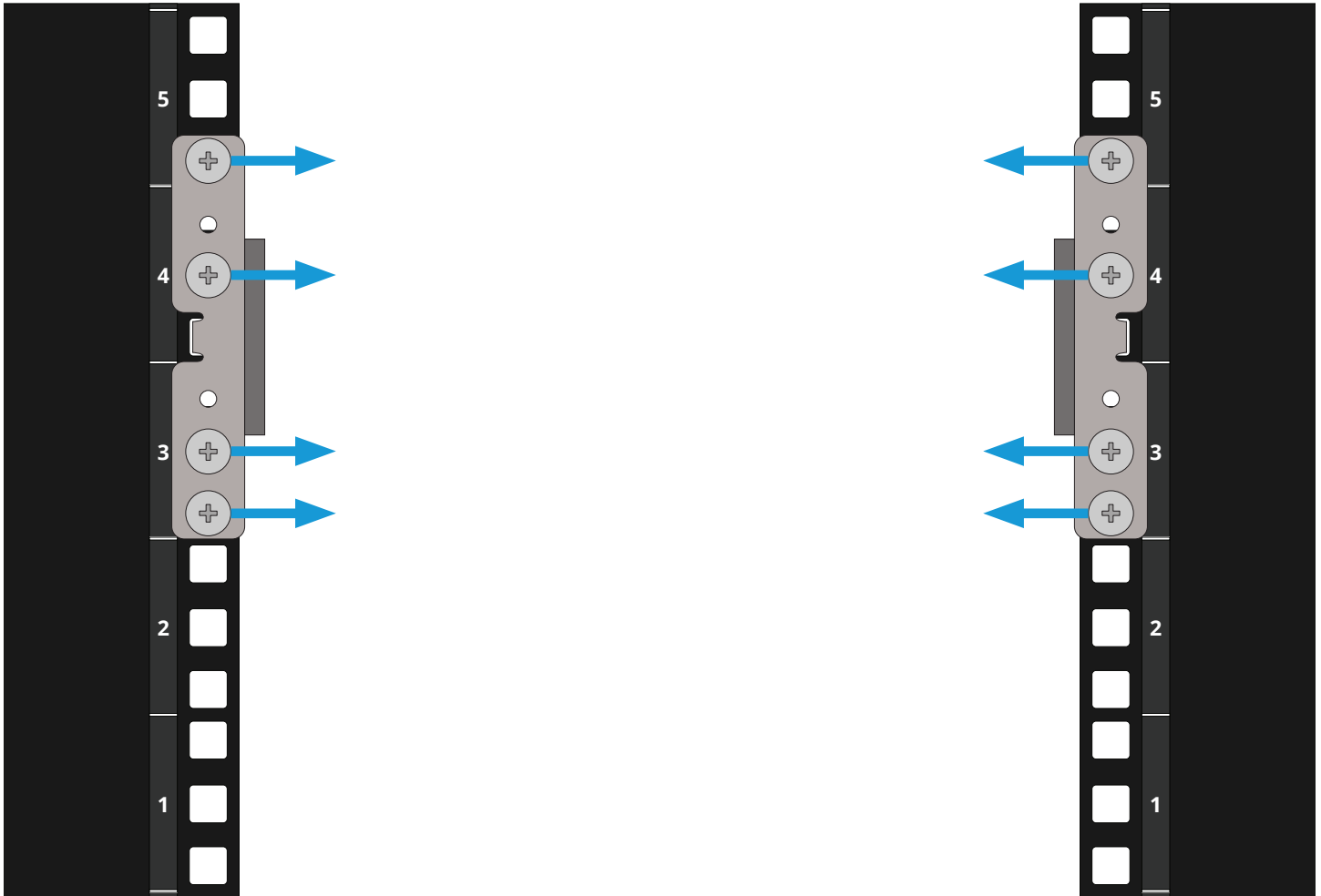

## 12.9 Uninstall Cage Nuts

Remove the six cage nuts from the front rack posts (three on each side).

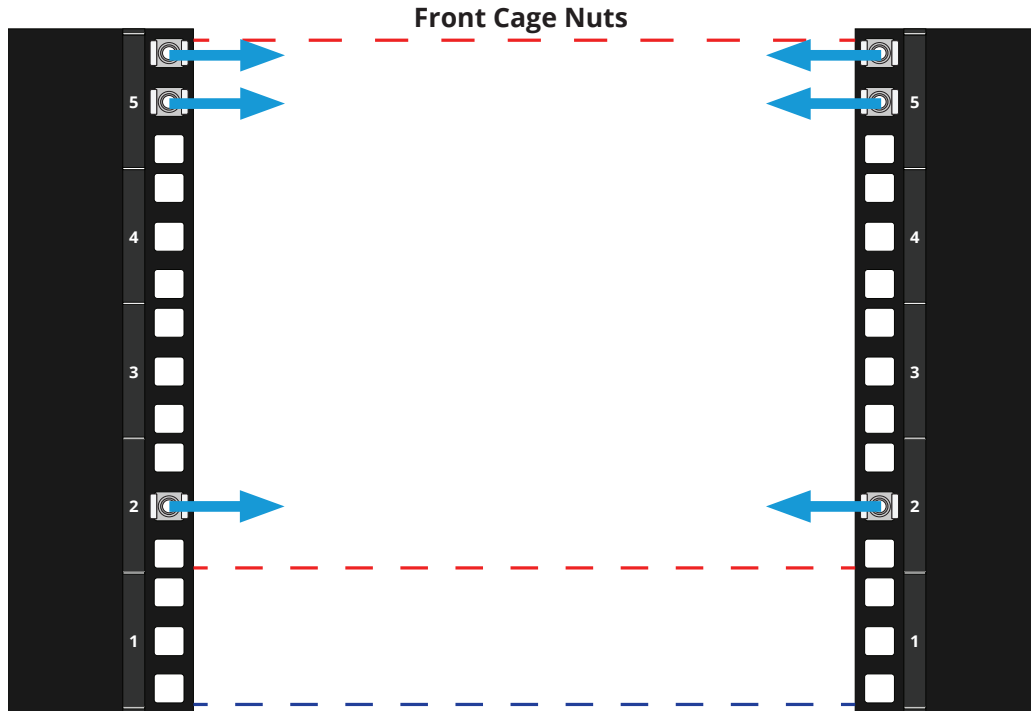

Remove the eight cage nuts from the rear rack posts (four on each side).

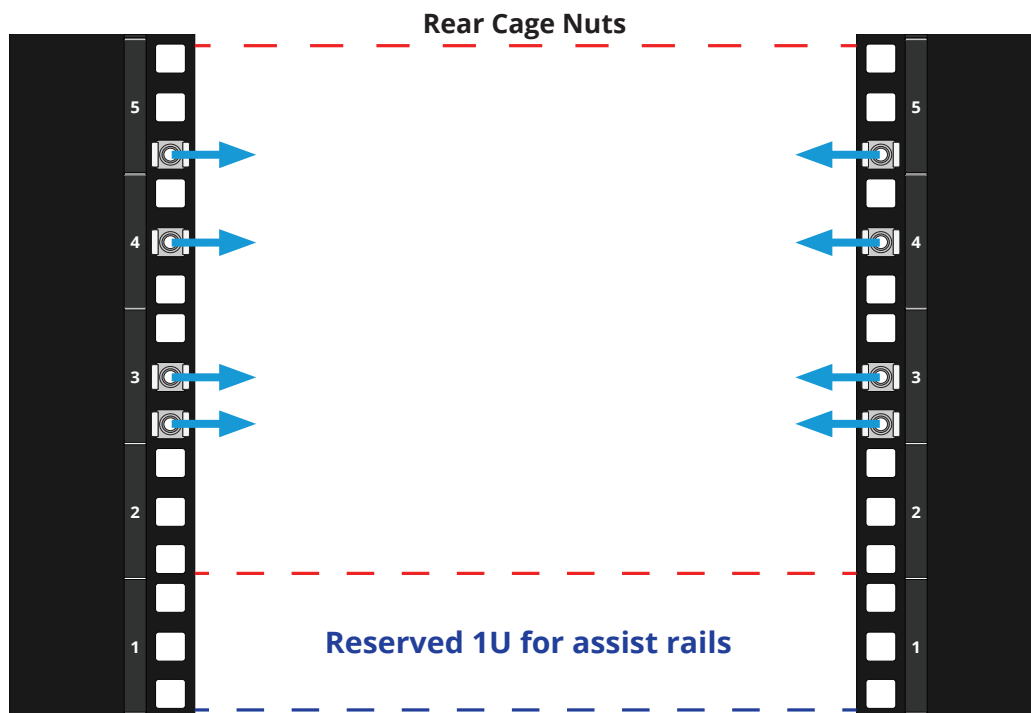

## 13 Drive Replacement

### 13.1 HDDs

Push the blue release tab on a slot cover and lift. Gently grasp the inner tray and pull it up until it locks into place.

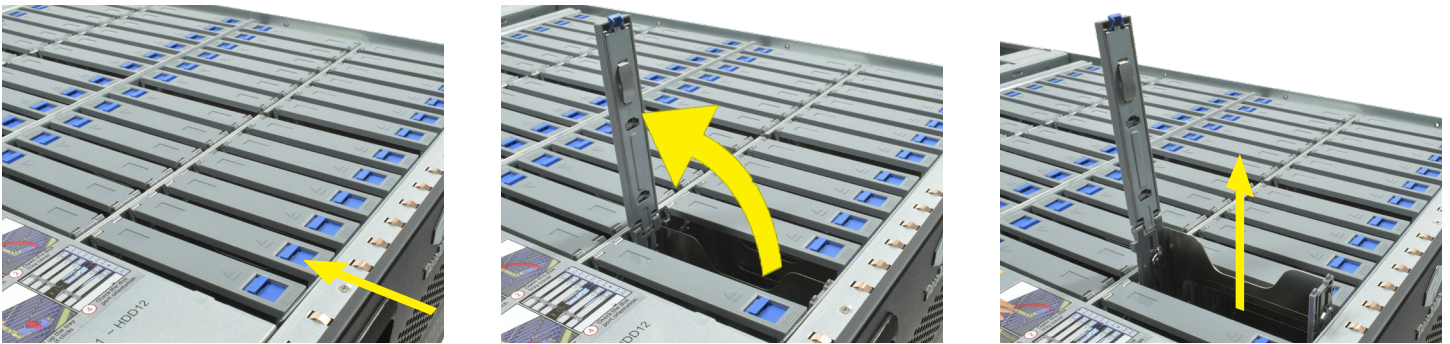

### 13.2 Remove NVMe Trays

#### ⓘ Note - NVMe Drive Integration

NVMe drives are hot-swappable, but the R50 won't add the drive until after a power cycle.

To remove an NVMe tray, press the release catch and gently pull the tray until it is out of the system.



### 13.3 Remove NVMe Drives

To remove an NVMe drive, push on it from underneath until it pops out of the side retention pegs. You may have to gently bend the tabs opposite the posts to get the drive out.



## 14 Additional Resources

The TrueNAS Documentation Hub has complete software configuration and usage instructions. Click **Guide** in the TrueNAS web interface or go directly to:

<https://www.truenas.com/docs>

Additional hardware guides and articles are in the Documentation Hub's Hardware section:

<https://www.truenas.com/docs/hardware>

The TrueNAS Forums provide opportunities to interact with other TrueNAS users and discuss their configurations:

<https://forums.truenas.com/>

## 15 Contact Us

Having issues? Please contact TrueNAS Enterprise Support to ensure a smooth resolution.

Contact Method	Contact Options
Web	<a href="https://www.truenas.com/support">https://www.truenas.com/support</a>
Email	<a href="mailto:support@truenas.com">support@truenas.com</a>
Telephone	Monday-Friday, 6:00AM to 6:00PM Pacific Standard Time: <ul style="list-style-type: none"><li>• US-only toll-free: <b>1-855-473-7449</b> option 2</li><li>• Local and international: <b>1-408-943-4100</b> option 2</li></ul>
Telephone	Telephone After Hours (24x7 Gold Level Support only): <ul style="list-style-type: none"><li>• US-only toll-free: <b>1-855-499-5131</b></li><li>• International: <b>1-408-878-3140</b> (International calling rates will apply)</li></ul>
Address	iXsystems, Inc. dba TrueNAS - 541 Division St, Campbell, CA 95008, USA